

5136545/2021/EPC/1-ENERGY  
 NOTE: DRAWING APPROVAL SUBJECT TO VALID TYPE TEST REPORTS, TO BE CHECKED DURING ACCEPTANCE TESTS.



Drawing approval subject to valid vendor registration

### FOR EPC CONTRACTS ONLY

CLIENT : TRANSMISSION CORPORATION OF ANDHRA PRADESH LIMITED, VIJAYAWADA

CONTRACTOR :

PO NO. 1) Minimum 300mm plinth shall be maintained for CT/PT/CVT/Isolators in the substation during foundation works to ensure safe live to ground clearances as per IE rules.

PROJECT 2) Since the supply of terminal connectors is not in the scope of manufacturer as mentioned in the drawings, the EPC contractors shall be instructed to supply the same in line with CT/PT/CVT/Isolators requirement and compatibility.

#### LIST OF DRAWINGS BEING SUBMITTED FOR 245 kV CT (LIVE TANK TYPE OSKF-245) CT RATIO: 600/1A (BAR TYPE PRIMARY)

SL	DRAWING NUMBER	DESCRIPTION OF DRAWING
01	Rev:00	GTP
02	411-B-10679 Rev:00	OUTLINE DIAGRAM
03	431-B-6802 Rev:00	RATING & CONNECTION PLATE
04	411-B-10680 Rev:00	SECTIONAL VIEW
05	422-B-5375 Rev:00	DETAIL OF SEC TERMINAL BOX

Note: Drawing Approval subject to valid type test reports to be checked during acceptance tests

	Chief Engineer		
	Power Systems, Planning & Design		
PRPD:	APTransco	CHKD:	APPRD:
SANGITH		SANGITH	MAYANK
24.03.2021		24.03.2021	24.03.2021

ISO : -----

⚠ CONTENTS OF THE DRAWING SHALL NOT BE MODIFIED WITHOUT PRIOR INTIMATION TO GE. REQUIRED CHANGES, IF ANY, SHALL BE HIGHLIGHTED OR MARKED AND COMMUNICATED TO GE FOR NECESSARY ACTION

This drawing is the property of GE T&D India Limited, This must be returned on request.  
 It is submitted as confidential in Connection with our enquiry/Tender No.-----  
 It is not to be used for any other purpose nor may it be copied or lent without our written permission.

## GUARANTEED TECHNICAL PARTICULARS FOR CURRENT TRANSFORMER

## 245kV CT RATIO - 600/1A



Sr. No.	Description	Technical Parameters
1	Manufacturer	GE T&D INDIA LIMITED, INDIA
2	CT Type	OSKF 245
3	Design	Live Head-type, Oil filled, Out door & Hermetically sealed
4	Max. Systems Voltage	245 kV
5	Nominal Systems Voltage	220 kV
6	Nominal Frequency	50 Hz
7	Lightning Impulse Withstand Voltage 1.2/50µS	1050 kV
8	Power Frequency Withstand Voltage (1 min)	460 kV
9	Switching Impulse Withstand Voltage - 250/2500µS (Wet)	N/A
10	Insulator	Porcelain
11	Nominal Creepage Distance	6125 mm
12	Color of Insulator	Brown
13	Standard applicable	IEC-61869-1&2
14	Rated Primary Current (contin.)	600A
15	Rated Primary Current (extended)	720A
16	Power Frequency Withstand Voltage between Secondary & Earth	5 kV for 1 min.
17	No. of Cores	1
18	Ratio	600/1 A
19	Core Data ( Burden & Accuracy Classes )	
	Core 1	5VA, 0.2S, ISF ≤ 5
	Core 2	-
	Core 3	-
	Core 4	-
20	Rated Short Time Thermal Current	40 kA / 1 sec.
21	Rated Short Time Dynamic Current	100 kAp
22	Radio Interference Voltage at 1.1 Ur/√3 at 1.0 Mhz	≤1000µV
23	Partial discharge level	10pC at Um, 5pC at 1.2 Um/√3 (Max)
24	Oil Standard (EHV Grade)	IEC 60296
25	Oil Quantity	155 Kgs
26	Oil Type	Mineral Oil
27	Dimensional details	
	a) Overall height from mounting plane (mm)	3450±100
	b) Height up to terminals from mounting plane (mm)	2990±90
	c) Mounting dimensions and diameter of mounting holes (mm)	450±10 x 450±10 (Hole to Hole); Mounting hole Ø20 x 4 nos
	d) Terminal pad dimensions (mm)	50mm Diameter; 105mm length
e) Material of primary terminal	Aluminium	
28	Details of Insulator	
	Make	BHEL/IEC/MODERN
	Type	Hollow
	Height (mm)	2270±10
	Inner diameter (mm)	160±5
	Cantilever strength	400kg
29	Seismic accelarition	0.3g
30	Corona Extinction Voltage	156 KVrms
31	Similar equipment type tested within the last 2 years	Yes
32	Transportation postion	Horizontal only
33	Overall general dimension drawing	Refer Outline Drawing
34	Total equipment weight	720kg
35	Tan delta	<0.005, As per IEC 61869-1&2

NOTE : DRAWING APPROVAL SUBJECT TO VALID TYPE TEST REPORTS, TO BE CHECKED DURING ACCEPTANCE TESTS.

1) Minimum 300mm plinth shall be maintained for CT/PT/CVT/Isolators in the substation during foundation works to ensure safe live to ground clearances as per IE rules.

2) Since the supply of terminal connectors is not in the scope of manufacturer as mentioned in the drawings, the EPC contractors shall be instructed to supply the same in line with CT/PT/CVT/Isolators requirement and compatibility.

PRPD  
Sangith.R  
24.03.2021

CHECKED  
Sangith. R  
24.03.2021

APPRD  
Mayank  
24.03.2021

Chief Engineer  
Power Systems, Planning & Design  
APTransco

Drawing approval subject to valid vendor registration

Signature \_\_\_\_\_ Date \_\_\_\_\_  
 This must be returned Tender No. .... our written permission.  
 GE T&D India Limited, Connection with our enquiry/ may it be copied or lent without our written permission.  
 This drawing is the property of GE T&D India Limited. It is submitted as confidential in on request. It is not to be used for any other purpose nor

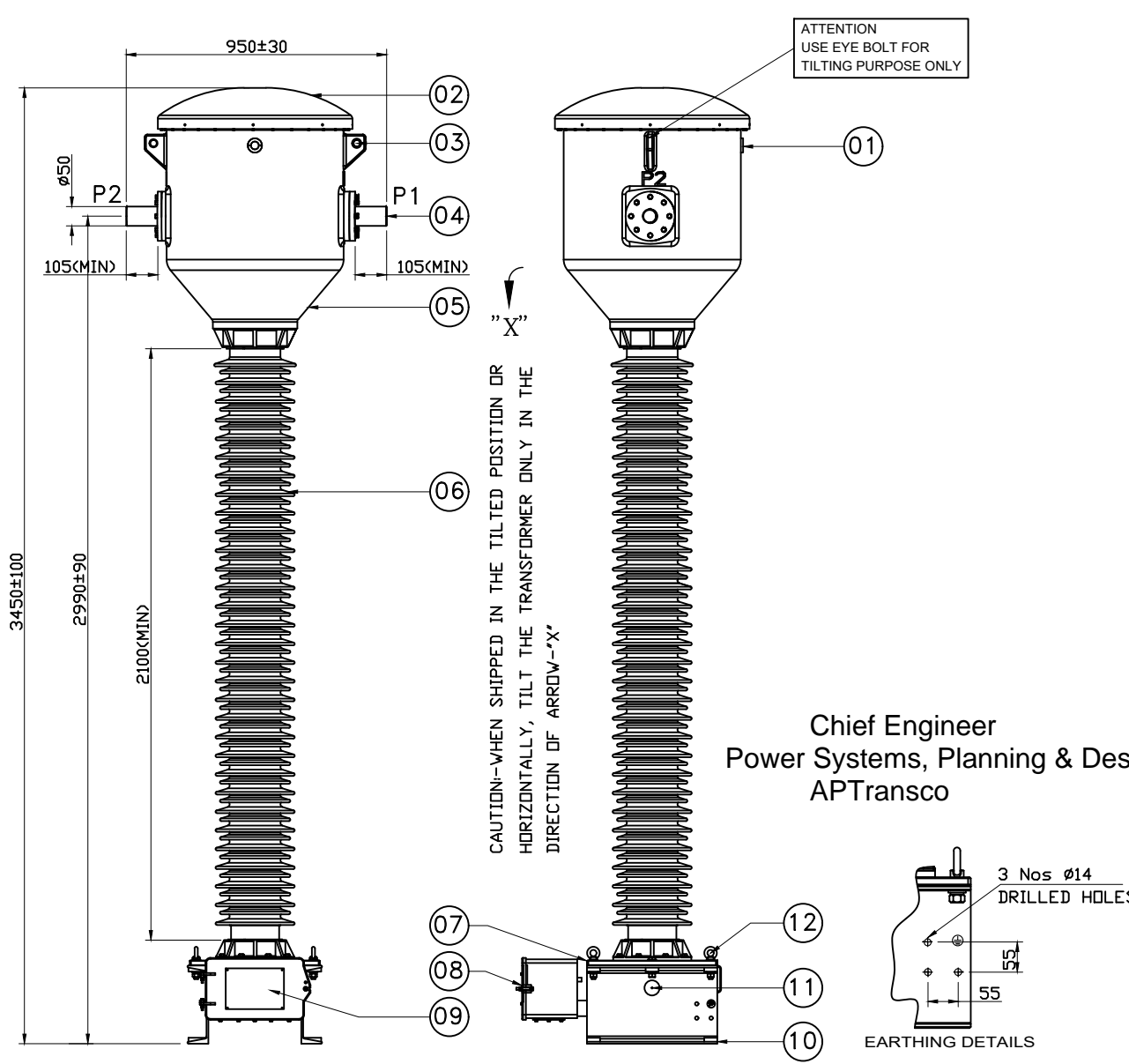

Chief Engineer  
Power Systems, Planning & Design  
APTransco

Drawing approval subject to valid vendor registration

IT.No.	DESCRIPTION	MATERIAL	QTY
1	OIL SIGHT GLASS	POLYCARBONATE	01
2	BELLOW COVER	ALUMINIUM	01
3	TANK LIFTING EYE	ALUMINIUM	02
4	PRIMARY BAR	ALUMINIUM ALLOY	01
5	TANK	ALUMINIUM	01
6	INSULATOR & END CASTING	PORCELAIN & GCI/AI	01
7	BASE PLATE	ALUMINIUM	01
8	SEC TERMINAL BOX	MS HDG / AL	01
9	RATING & SCHEMATIC PLATE	STAINLESS STEEL	01
10	MOUNTING CHANNEL/EARTHING PAD	MS HDG	02
11	OIL DRAIN DEVICE	BRASS	01
12	EYE BOLTS FOR LIFTING	STAINLESS STEEL	04

- NOTES :-
- NOMINAL CREEPAGE DISTANCE: 6125 mm.(25mm/kV)
  - TOTAL WEIGHT OF C.T : 720 Kgs (Approx.)
  - TOTAL SHIPPING WEIGHT: 1000 Kgs (Approx.)
  - MAKE OF INSULATOR :- BHEL / IEC / MODERN
  - GENERAL TOLERANCE WILL BE APPLICABLE WHERE TOLERANCE IS NOT INDICATED
  - MINOR MODIFICATION WITHOUT NOTICE
  - ALL FERROUS PARTS SHALL BE HOT DIP GALVANIZED
  - OIL COMPLIANCE STANDARD - IS:335 / IEC:60296

ELECTRICAL PARAMETERS :-

RATED SYSTEM VOLTAGE	: 220 kV
HIGHEST SYSTEM VOLTAGE	: 245 kV
APPLICABLE STANDARD	: IEC:61869-1&2
RATED PRIMARY CURRENT	: 600 A
RATED EXTENDED PRIMARY CURRENT	: 120% OF RATED PRIMARY CURRENT
INSULATION LEVEL	: 245/460/1050 kV (Peak)
SHORT TIME CURRENT	: 40 kA FOR 1 Sec.
DYNAMIC CURRENT	: 100kA (Peak)
RIV at 156 kV	: < 1000 µV

CT RATIO: 600/1A (BAR TYPE PRIMARY)

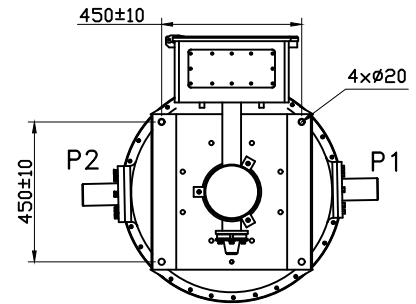

REVISION	DESCRIPTION
It.	

	NAME	DATE	ALL DIMENSIONS ARE IN mm. UNLESS OTHERWISE SPECIFIED.	SCALE : NTS
DRN.	SANGITH	24.03.2021	OUTLINE DIAGRAM FOR 245 kV CT (LIVE TANK TYPE OSKF-245) (120% EXTENDED PRIMARY CURRENT)	REF: -----
CHD.	SANGITH	24.03.2021		
APPD.	MAYANK	24.03.2021		



GE T&D India Limited

DRG.No.  
411-B-10679  
Rev:00

Drawing approval subject to valid vendor registration



**GE T&D INDIA LIMITED**  
MADE IN INDIA

**CURRENT TRANSFORMER**  
AS PER IEC 61869-1&2

SL.No./YEAR							CUSTOMER	TRANSMISSION CORPORATION OF ANDHRA PRADESH LIMITED, VIJAYAWADA		
RATIO (A/A)	600/1						TYPE	-	OSKF 245	
CORE NUMBER	1	2	3	4	5	6	HSV/NSV	kV	245/220	
ACCURACY CLASS	0.2S	-	-	-	-	-	BIL	KV(r.m.s)/kVp	460/1050	
ISF/ALF	≤ 5	-	-	-	-	-	FREQUENCY	Hz	50	
OUTPUT (VA)	5	-	-	-	-	-	RTD. CONT. CURRENT	A	600	
KPV (V)	-	-	-	-	-	-	RTD. EXT. CURRENT	A	720	
I <sub>exc</sub> at V <sub>k</sub> (mA)	-	-	-	-	-	-	RTD. THER. CURRENT	A	-	
R <sub>ct</sub> at 75°C (Ohms)	-	-	-	-	-	-	I <sub>th</sub>	kA/S	40/1	
SECONDARY CONNECTION	P1-P2	600/1	1S1-1S2S' (SHORT 1S2 S')	-	-	-	I <sub>dyn</sub>	kA	100	
	-	-	-	-	-	-	OIL WEIGHT	Kg	155	
	-	-	-	-	-	-	TOTAL WEIGHT	Kg	720	
	-	-	-	-	-	-	INSULATION CLASS	-	CLASS "A"	
	-	-	-	-	-	-	NOMINAL CREEPAGE	mm	6125	

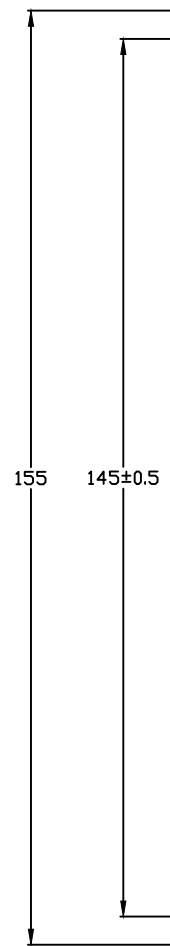

**SCHEMATIC DIAGRAM AND CONNECTION**

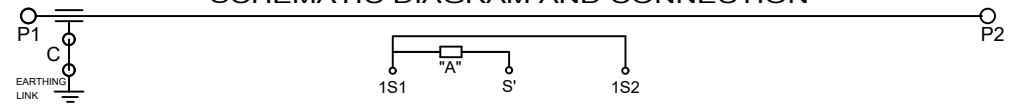

**ATTENTION**  
01. L.V. BUSHING SHOULD ALWAYS BE EARTHED & DISCONNECTED ONLY FOR TAN DELTA MEASUREMENT  
02. EARTHING LINK TO BE RECONNECTED FIRMLY BEFORE ENERGISING CURRENT TRANSFORMER

"A" - COMPENSATING CORE TO MEET ISF  
**NOTES:-**  
01. INSULATION OIL TYPE : MINERAL OIL (IS 335 / IEC 60296)  
02. TEMPERATURE CATEGORY : -5°C TO 40°C (AS PER IEC 61869-1; CLAUSE-4.2.1)  
03. STATIC LOAD WITHSTAND : 4000N (AS PER IEC 61869-1; CLAUSE-6.7)  
04. "C" - CAPACITANCE/TAN DELTA POINT

**⚡ DANGER:- VOLTAGE RISE WHEN SECONDARY IS OPENED**

431-B-6802 Rev:00

Chief Engineer  
Power Systems, Planning & Design  
APTransco

Ø4 X 4 HOLES

**NOTES:-**  
OUTDOOR PROOF (MATERIAL : STAINLESS STEEL - 0.5 mm THICK )

CT RATIO: 600/1A (BAR TYPE PRIMARY)				SCALE : NTS
DRN.	SANGITH	24.03.2021	ALL DIMENSIONS ARE IN mm. UNLESS OTHERWISE SPECIFIED.	REF: -----
CHD.	SANGITH	24.03.2021		
APPD.	MAYANK	24.03.2021		
RATING & CONNECTION PLATE FOR 245 kV CT (LIVE TANK TYPE OSKF-245) (120% EXTENDED PRIMARY CURRENT)				
<b>GE T&amp;D India Limited</b>				DRG.No. 431-B-6802
				Rev:00

Signature \_\_\_\_\_ Date \_\_\_\_\_  
 This must be returned Tender No. .... our written permission.  
 GE T&D India Limited, Connection with our enquiry/ may it be copied or lent without  
 This drawing is the property of on request. It is submitted as confidential in It is not to be used for any other purpose nor  
 REVISION  
 DESCRIPTION  
 It.

Signature \_\_\_\_\_  
Date \_\_\_\_\_

This must be returned  
Tender No. ....  
our written permission.

GE T&D India Limited,  
Connection with our enquiry/  
may it be copied or lent without

This drawing is the property of  
on request. It is submitted as confidential in  
It is not to be used for any other purpose nor

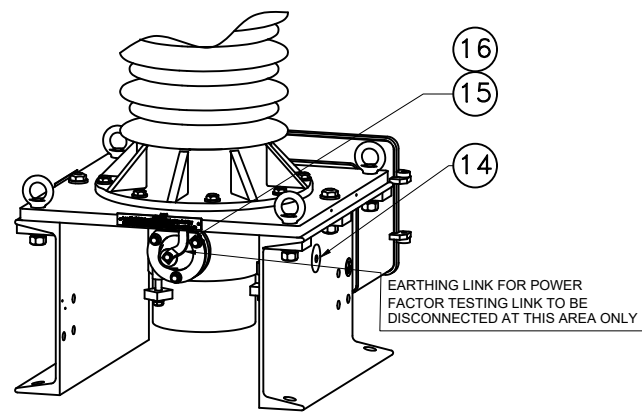
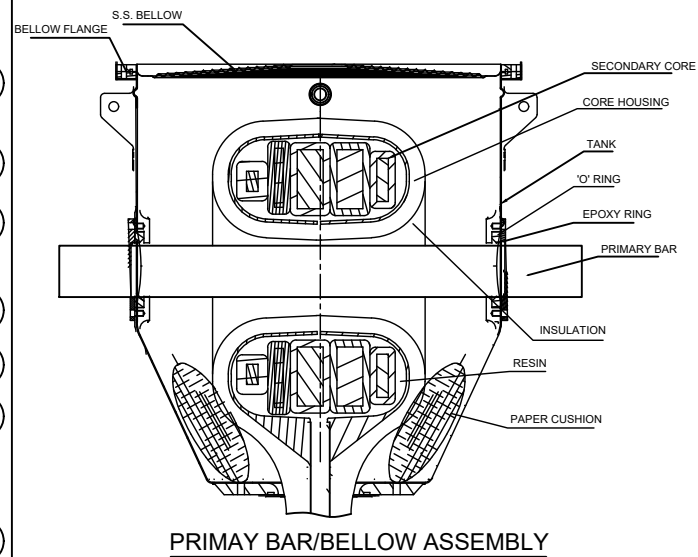
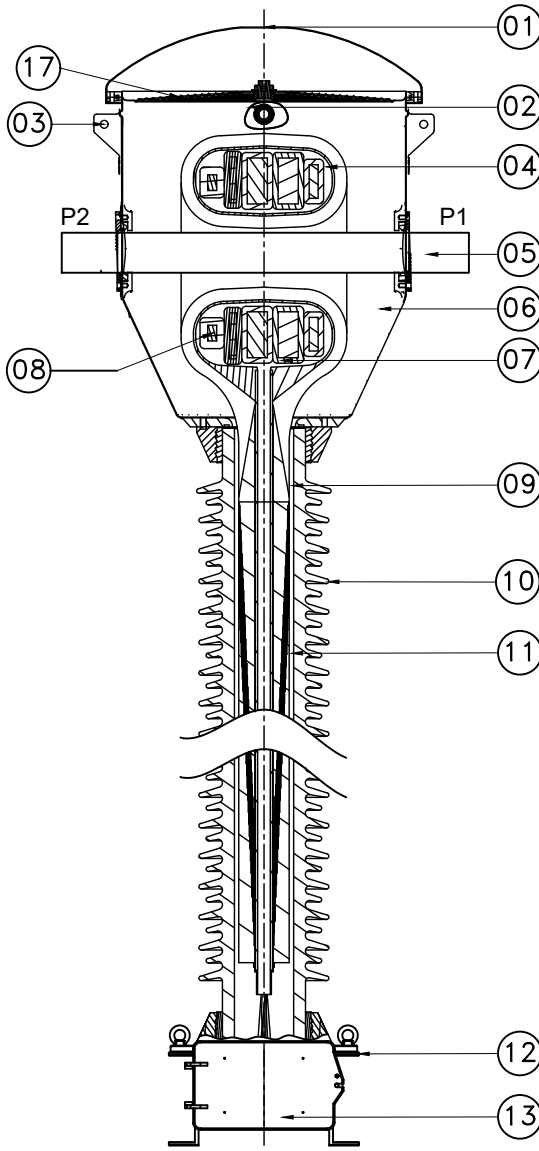

IT.No.	DESCRIPTION	MATERIAL	23
01	BELLOW COVER	ALUMINIUM ALLOY	513
02	OIL SIGHT GLASS	POLYCARBONATE	
03	TANK LIFTING EYE	ALUMINIUM ALLOY	
04	HEAD INSULATION	PAPER	
05	PRIMARY TERMINAL	ALUMINIUM ALLOY	
06	TANK	ALUMINIUM ALLOY	
07	SECONDARY CORES	CRGO/SPL ALLOY	
08	SECONDARY WINDING	COPPER	
09	OIL	MINERAL OIL	
10	INSULATOR	PORCELAIN	
11	ACTIVE PART	PAPER	
12	BASE PLATE	ALUMINIUM	
13	SECONDARY TERMINAL BOX	MS HDG WITH AL. COVER	
14	OIL DRAIN VALVE	BRASS	
15	LV BUSHING FOR TAN DELTA & CAPACITANCE MEASUREMENT	COPPER-TERMINAL EPOXY- BUSHING	
16	EARTHING LINK FOR LV BUSHING	COPPER	
17	BELLOW	STAINLESS STEEL	

**PRIMARY WINDING DETAILS :-**

NO. OF PRIMARY TURN : ONE  
 PRIMARY CONDUCTOR MATERIAL : ALUMINIUM ALLOY  
 CROSS SECTIONAL AREA : 1963 Sq.mm

**SECONDARY WINDING DETAILS :-**

NO. OF SECONDARY TURNS : 600  
 SEC. CONDUCTOR MATERIAL : SUPER ENAMELLED COPPER WIRE  
 CROSS SECTIONAL AREA : 19 SWG - 14 SWG

<b>CT RATIO: 600/1A (BAR TYPE PRIMARY)</b>				
	NAME	DATE	ALL DIMENSIONS ARE IN mm. UNLESS OTHERWISE SPECIFIED.	SCALE : NTS
DRN.	SANGITH	24.03.2021	<b>SECTIONAL VIEW</b> FOR 245 kV CT (LIVE TANK TYPE OSKF-245) (120% EXTENDED PRIMARY CURRENT)	REF: -----
CHD.	SANGITH	24.03.2021		
APPD.	MAYANK	24.03.2021		

**Chief Engineer**  
 Power Systems, Planning & Design  
 APTransco



**GE T&D India Limited**

DRG.No.  
**411-B-10680**  
Rev:00

Signature \_\_\_\_\_  
Date \_\_\_\_\_

This must be returned  
Tender No. ....  
our written permission.

GE T&D India Limited,  
Connection with our enquiry/  
may it be copied or lent without

This drawing is the property of  
on request. It is submitted as confidential in  
It is not to be used for any other purpose nor

Drawing approval subject to valid vendor registration

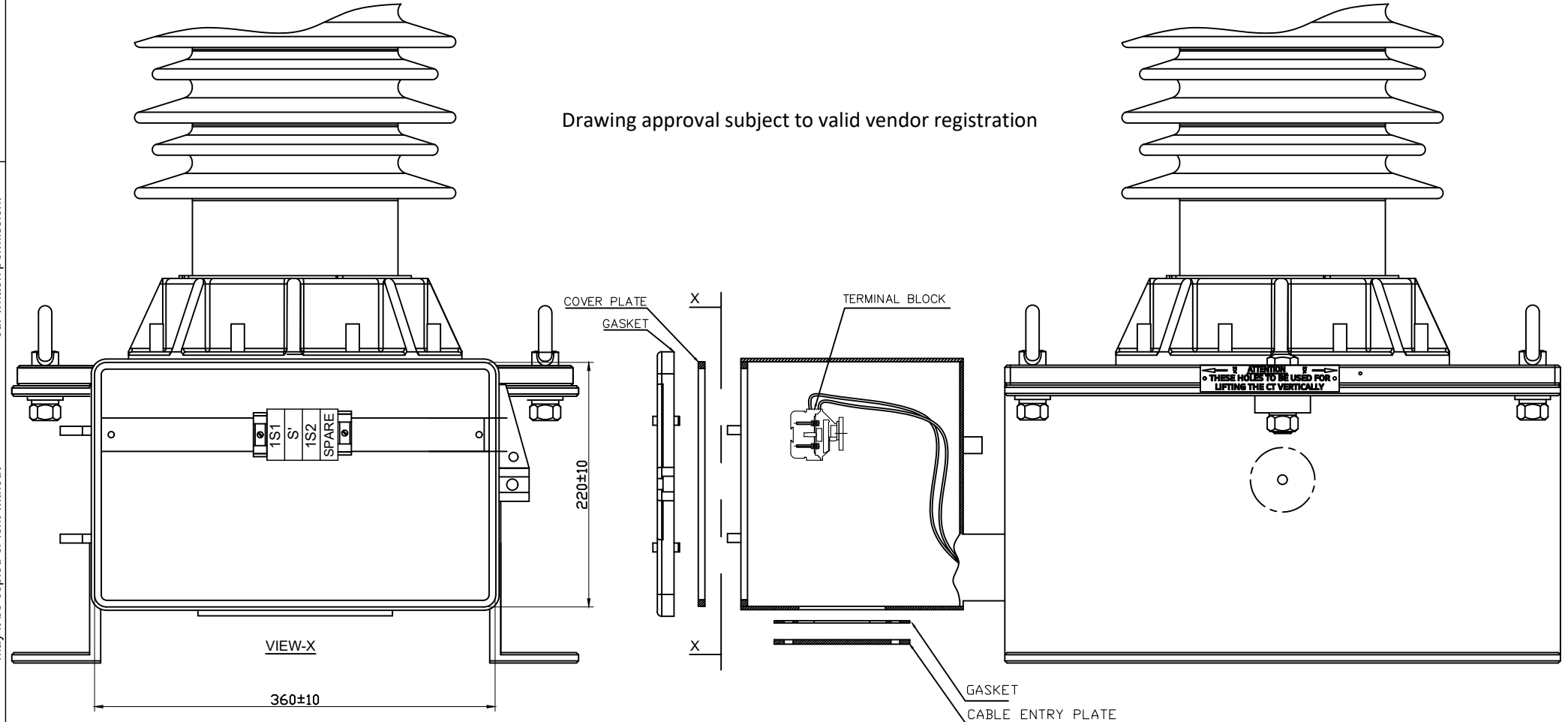

LEGEND

1. M6 STUD TYPE SECONDARY TERMINAL OF 750V GRADE SUITABLE FOR 4 - 6SQ.MM CABLE SIZE WITH NECESSARY SHORTING LINK  
MAKE : ELMEX / CONNECTWELL
2. GASKET. (TYPE : NEOPRENE / EPDM)
3. CABLE ENTRY ALUMINIUM PLATE (278 x 122 x 4)

NOTES:

1. TERMINAL BOX CONFORMS TO IP:55 DEGREE PROTECTION AS PER IS/IEC60947-1:2004
2. 1 No.3/4" DOUBLE COMPRESSION CABLE GLANDS IN THE SCOPE OF GE SUPPLY.

CT RATIO: 600/1A (BAR TYPE PRIMARY)			
	NAME	DATE	ALL DIMENSIONS ARE IN mm. UNLESS OTHERWISE SPECIFIED.
DRN.	SANGITH	24.03.2021	DETAIL VIEW OF SEC. TERMINAL BOX FOR 245 kV CT (LIVE TANK TYPE OSKF-245) (120% EXTENDED PRIMARY CURRENT)
CHD.	SANGITH	24.03.2021	
APPD.	MAYANK	24.03.2021	
			SCALE : NTS
			REF: -----

REVISION	DESCRIPTION
It.	

Chief Engineer  
Power Systems, Planning & Design  
APTransco



GE T&D India Limited

DRG.No.  
422-B-5375  
Rev:00