

NOTE: 1. Drawings Approval subject to valid type test reports, to be checked during acceptance tests.  
 7613129/2023/FEMRT-ENE51

Drawing approval subject to valid vendor registration

2.For EPC contractors only.

Index	Amendment/Revision	Date	Name	The reproduction transmission of use of this document or its contents is not permitted without express written authority. Offenders will be liable for damages. All rights, including rights created by patent grant or registration of a utility model or design are reserved.	Index	Amendment/Revision	Date	Name
A					E			
B					F			
C					G			
D					H			

Sr. No.	Drawing No.	No. of Sh	Brief details of drawings	Amendment to RECORD OF DRAWINGS										Qty of Prints	
				A	B	C	D	E	F	G	H	I	J		
1	( 3 ) G 7 1 A H S - N A 4 0 3 - D 1 5 0 3 - - - - -	3	Design Details												
2	( 3 ) G 7 1 A H S - N A 4 0 3 - Z 1 5 0 3 - - - - -	2	GA Drawing/ Support Structure												
3	( 3 ) G 7 1 A H S - N A 4 0 3 - N 1 5 0 3 - - - - -	2	Rating Plate												
4	( 3 ) G 7 1 A H S - N A 4 0 3 - L 1 5 0 3 - - - - -	3	Equipment Layout (Front/Rear)												
5	( 3 ) G 7 1 A H S - N A 4 0 3 - W 1 5 0 3 - - - - -	9	Wiring Diagram												
6	( 3 ) G 7 1 A H S - N A 4 0 3 - T 1 5 0 3 - - - - -	18	Terminal Plan												
7	( 3 ) G 7 1 A H S - N A 4 0 3 - E 1 5 0 3 - - - - -	10	Equipment List												
8	( 3 ) G 7 1 A H S - N A 4 0 3 - C 1 5 0 3 - - - - -	4	Chamber and support Insulator												
9	( )														
10	( )														
11	( )														
12	( )														

**CLIENT: Transmission Corporation of Andhra Pradesh Limited**  
**CONTRACTOR: As Applicable**  
**PROJECT: As Applicable**  
**PO.NO.: As Applicable**

**CHIEF ENGINEER/PROJECTS**  
**APTRANSCO/VISVIJAYAWADA**

<b>Drg Codes</b>	C = Construction Details; D = Design Details / Tech Details; E = Equipment List; L = Equipment Layout ( Front, Rear); N = Name Plate / Rating Plate; R = Record of Drawings; S = Single Line Diagram; W = Wiring Drawing / Power & Control Circuit; Z = Any Drawing not covered by other code.										
Date	09.05.2023	Siemens Ltd. Aurangabad	<b>Descr:</b> 245kV,50kA,4000A,SF6 CB <b>Type:</b> 3AP1FI <b>Details:</b> RECORD OF DRAWING	Sales Ref.:	Qty:	=					
Prep.	MSR										
Ckd.	SB										
Norm											
Original/Replacement for/Replaced by:-											
<b>Drg No.:</b> ( 4 ) G 7 1 A H S - N A 4 0 3 - R 1 5 0 3 - - - - -										Sh 1	
										1 Sh	

7613129/2023/EEMRT-ENE51  
 acceptance tests.  
 2.For EPC contractors only.

# SIEMENS

## DESIGN DETAILS

<b>1.0</b>	<b>General</b>		
1.1	Type Designation	Siemens Make 3AP1FI	
1.2	Governing Standard	IEC 62271-100	
<b>2.0</b>	<b>Technical Data</b>		
2.1	System Parameters		
.1	Rated Voltage	kV	245 kV
.2	Frequency	Hz.	50
.3	No. of Poles		Three
.4	Ambient Temperature Range	°C	-30 to +55
<b>3.0</b>	<b>Operating Data</b>		
3.1	Type of Operating Mechanism	Spring Energy Stored	
3.2	Mechanism is electrically gang operated	Yes	
3.3	Operating Data		
.1	Closing	mSec.	62± 7
.2	Breaking	mSec.	60
.3	Opening Time	mSec.	35± 4
.4	Arcing Time	mSec.	≤25
3.4	Switching Data		
.1	Rated normal current	A	4000
.2	Rated short circuit breaking current	kA	50
.3	Rated short time current	kA	50, (3sec.)
.4	Rated short circuit making current	kAp	125
.5	First pole to clear factor		1.3
.6	Out-of-phase breaking current	kA	12.5
.7	Rated line charging breaking current	A	125
.8	Rated cable charging breaking current	A	250
3.5	Rated operating sequence	O – 0.3sec – CO – 3min – CO	

**CHIEF ENGINEER/PROJECTS**  
**APTRANSCO/VS/VIJAYAWADA**

CLIENT: Transmission Corporation of Andhra Pradesh Limited				Sales Ref.:		Qty.:	
CONTRACTOR: As Applicable							
PROJECT: As Applicable							
PO.NO.: As Applicable							
				Date: 09.05.2023	Description: - 245kV,50kA, 4000A SF6 CB.		Sh. 1
				Prepared: MSR			
				Checked: SB	Type: - 3AP1FI		3 Sh.
				Siemens Ltd.			
Issue	Remarks	Date	Name	Office	Details: - DESIGN DETAILS		
Original/Replacement for/ Replaced by :-				Dwg No. :- (3)G71AHS-NA403-D1503-			

# SIEMENS

<b>4.0</b>	<b>Basic Insulation Level</b>			
4.1	Rated power frequency withstand voltage (1min, 50 Hz)			
	.1 Phase to earth	kV	460	
	.2 Across the open breaker	kV	460	
	.3 Between phases	kV	460	
4.2	Rated lighting impulse withstand voltage (1.2 / 50 micro sec.)			
	.1 To earth	kVp	1050	<b>CHIEF ENGINEER/PROJECTS APTRANSCO/VISVIJAYAWADA</b>
	.2 Across the open breaker	kVp	1050	
	.3 Between phases	kVp	1050	
4.3	Creepage distance			
	.1 To earth	mm	6125 mm (25 mm/kV)/ [REDACTED] cable	
	.2 Insulator type		Hollow porcelain	
<b>5.0</b>	<b>Construction</b>			
5.1	Clearance			
	.1 To earth	mm	1900	
	.2 Across the open breaker	mm	1900	
	.3 Phase to phase	mm	4500	
5.2	Arc quenching Medium			<b>CHIEF ENGINEER /PROJECTS APTRANSCO/VISVIJAYAWADA</b>
	.1 Nominal pressure SF6 (@20°C)	bar	6.0 rel.	
	.2 Signal Loss of SF6 (@20°C)	bar	5.2 rel.	
	.3 General lockout (@20°C)	bar	5.0 rel.	
	.4 Quantity of SF6 gas required per pole of the breaker.	kg	5.5	
	.5 Breaker Poles (3nos.) will be prefilled with the transport pressure of SF6 gas.	Bar	0.5 (3kg Approx.)	
	.6 Gas being supplied per breaker	kg	16.5	
5.3	Installation		Outdoor	
5.4	Approx. weight of the breaker. (Without support structure)	kg	2000 approx. (25mm/kV) / [REDACTED]	
<b>6.0</b>	<b>Structures</b>			
6.1	Material		Mild Steel	
6.2	Surface Treatment		Hot Dip Galvanized	

CLIENT: Transmission Corporation of Andhra Pradesh Limited				Sales Ref.:		Qty.:	
CONTRACTOR: As Applicable							
PROJECT: As Applicable							
PO.NO.: As Applicable							
				Date: 09.05.2023	Description: - 245kV,50kA, 4000A SF6 CB.		Sh. 2
				Prepared: MSR			
				Checked: SB	Type: - 3AP1FI		3 Sh.
				Siemens Ltd.			
Issue	Remarks	Date	Name	Office	Details: - DESIGN DETAILS		
Original/Replacement for/ Replaced by :-				Dwg No. :- (3)G71AHS-NA403-D1503-			

**SIEMENS****7.0 Base Frame**

7.1	Material	Mild Steel
7.2	Surface Treatment	Hot Dip Galvanized

**8.0 Control Cubicle**

8.1	Construction		
.1	Material of enclosure	CR Sheet Steel	
.2	The thickness of sheet steel	2.5	mm
.3	Painting for control cubicle	Epoxy / Polyester Paint	
.4	Internal / External shade	631 As per IS:5	
.5	Degree of protection of the enclosure	IP 55	
.6	Padlocking facility for cubicle	Provided	
.7	Glass window to see spring status	Provided on control cubicle	
8.2	Wiring		
.1	Control wiring		
.1	Control cabinet wire	2.5 sq. mm, flexible copper conductor	
.2	Interpole cable	2.5 sq. mm, armored flexible copper conductor	
.3	Insulation	Grey - DC & Black – AC, 1100V Grade	
.2	Earth Wiring		
.1	Size	2.5 sq. mm, flexible copper conductor	
.2	Insulation	Yellow Green 1100V Grade	
8.3	Control Terminals		
.1	Type	Stud type	
.2	Make	Connectwell / Elmex	
.3	Size	4.0	mm <sup>2</sup>
.4	Spare unwired terminal	10(max)	Nos.
8.4	Auxiliary Supply		

Circuit	Rated Voltage	Source	Range
Spring Charging Motor	240V AC	External	85 – 110%
Closing Coil (330W)	220V DC	External	85 – 110%
Trip Coil – 1 & 2 (330W)	220V DC	External	70 – 110%
Space Heater / Socket / Illumination	240V AC	External	--

**CHIEF ENGINEER/PROJECTS**  
**APTRANSCO/VS/VIJAYAWADA**

Drawing approval subject to valid vendor registration

CLIENT: Transmission Corporation of Andhra Pradesh Limited				Sales Ref.:		Qty.:	
CONTRACTOR: As Applicable							
PROJECT: As Applicable							
PO.NO.: As Applicable							
				Date: 09.05.2023	Description: - 245kV,50kA, 4000A SF6 CB.		Sh. 3
				Prepared: MSR			
				Checked: SB	Type: - 3AP1FI		3 Sh.
				Siemens Ltd.			
Issue	Remarks	Date	Name	Office	Details: - DESIGN DETAILS		
Original/Replacement for/ Replaced by :-						Dwg No. :- (3)G71AHS-NA403-D1503-	

The reproduction, transmission or use of this document or its contents is not permitted without express written authority of the authority. All rights, including rights created by patent grant or registration of a utility model or design, are reserved.

NOTE: 1. Drawings Approval subject to valid type test reports, to be checked during acceptance tests.  
2. For EPC contractors only.

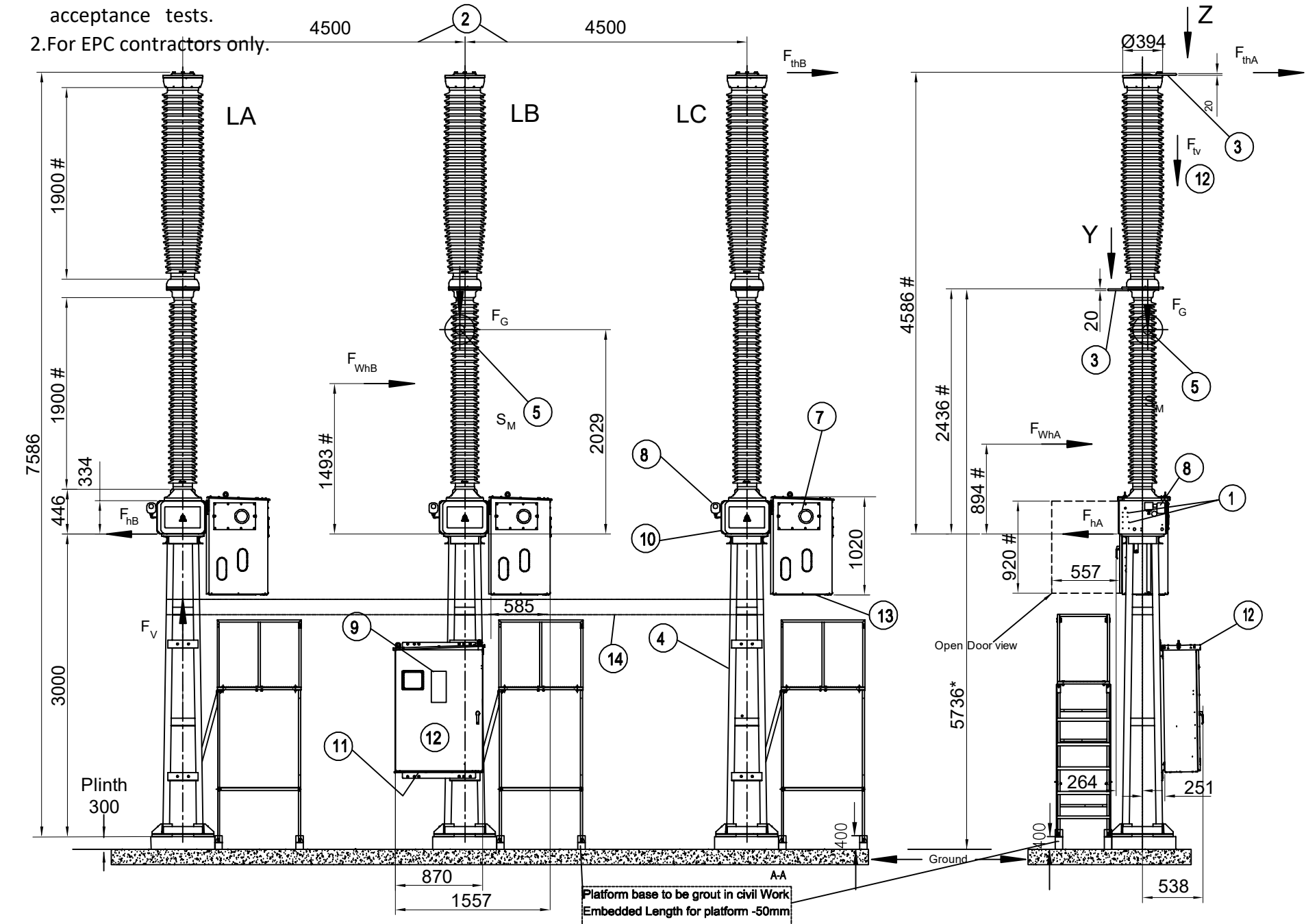

**Bill of Materials :-**

1. Pole - 3 nos.
2. Spring Operating Mechanism+baseframe- 3 nos.
3. Marshalling Box (Fixed on B Pole) - 1 nos.
4. Interpole cable - 2.5 mm<sup>2</sup> Armored.
5. Support Structure - 3 Nos.
6. Foundation Bolts - 12 Nos.
7. Platform - 3 Nos.

**Legends :-**

1. Holes for earthing terminals
2. Pole to pole distance
3. Aluminium Terminal plates with holes (#thick 20mm)
4. Support structure
5. Center of Gravity
6. Insulator creepage: 25 mm/kv / 30 mm/kv (As applicable)\*.  
Make:- ABIL/Modern/IEC.
7. Mechanical "on/off" indication
8. Pressure gauge
9. Rating plate
10. Base frame
11. Gland plate location at bottom of panel.
12. Marshalling Box
13. Operating Mechanism Box
14. Cable Tray.
15. Platform.

**Note:**

- Mass of CB (without structure) = 2000 kg approx. (25mm/kV)
- Mass of CB (without structure) = 2250 kg approx. (31mm/kV)
- Mass of heaviest part (pole) = 550 kg approx.
- Mass of SF6 gas per CB = 16.5 kg approx.
- Rated pressure of SF6 gas at 20°C= 6 bar (gauge)

Loads per pole					
F <sub>G</sub>	F <sub>WhA</sub>	F <sub>WhB</sub>	F <sub>hA</sub>	F <sub>hB</sub>	F <sub>V</sub>
Weight Loads	Wind Loads, at a Wind speed of 34m/s		Operating Loads Horizontal		Operating Loads Vertical
8.4 kN	2.0 kN	1.4 kN	0 kN	6.5 kN	+23.0 kN(pull) -28.0 kN(push)

- Terminal Pad Current Density = 1.0 A / sq. mm
- Minor deviations from the dimensions and the data stated are permissible.
- Earth Terminals M12, DIN 46 011 and NEMA.
- '\*' marked dimensions can be changed to suit the site requirements.
- '# ' marked are standard design dimensions which cannot be changed.

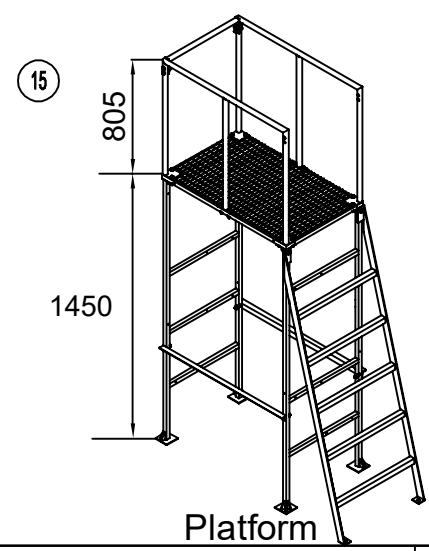
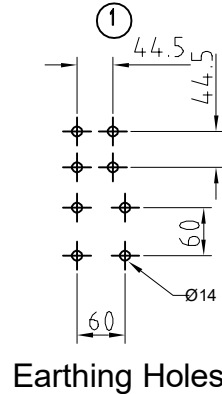
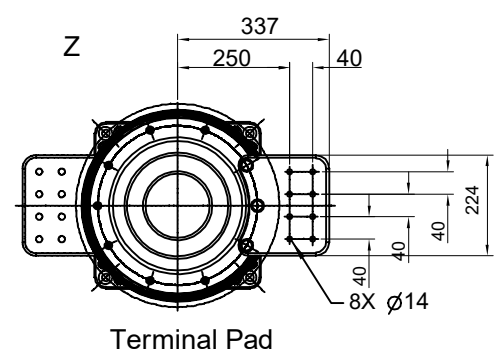

Platform base to be grout in civil Work  
Embedded Length for platform -50mm

**CHIEF ENGINEER/PROJECTS  
APTRANSCO/VISVIJAYAWADA**

H0/ESD-Coord/9E 03-90	Date	09.05.2023	CLIENT: Transmission Corporation of Andhra Pradesh Limited	SIEMENS	Descr : 245kV,50kA,4000A SF6 CB.	SO No :	Qty:	1HG-594-03542-001
	Prep	MSR	CONTRACTOR: As Applicable					
Issue	Remarks	Date	Name	Norm.	Original / Replacement for /Replaced by :-	Drg. No:- (3)G71AHS-NA403-Z1503		Sh. 1 2 Sh.

The reproduction, transmission or use of this document or its contents is not permitted without express written authority of the originator. All rights, including rights created by patent grant or registration of a utility model or design, are reserved.

NOTE: 1. Drawings Approval subject to valid type test reports, to be checked during acceptance tests.  
2. For EPC contractors only.

1. Minimum 300mm plinth shall be maintained for CT/PT/CVT/Isolators/IV/LA/Breakers in the substation during foundation works to ensure safe live to ground clearance per IE rules.
2. Since the supply of terminal connectors is not in the scope of manufacturer as mentioned in the drawings. The EPC contractor shall be instructed to supply the same line with CT/PT/CVT/Isolator/IVT/LA/Breaker's requirement and compatibility.

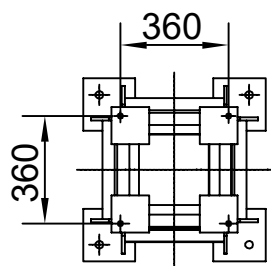

Drawing approval subject to valid vendor registration

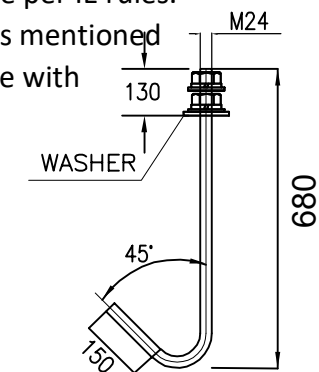

**DETAILS OF FOUNDATION BOLT**

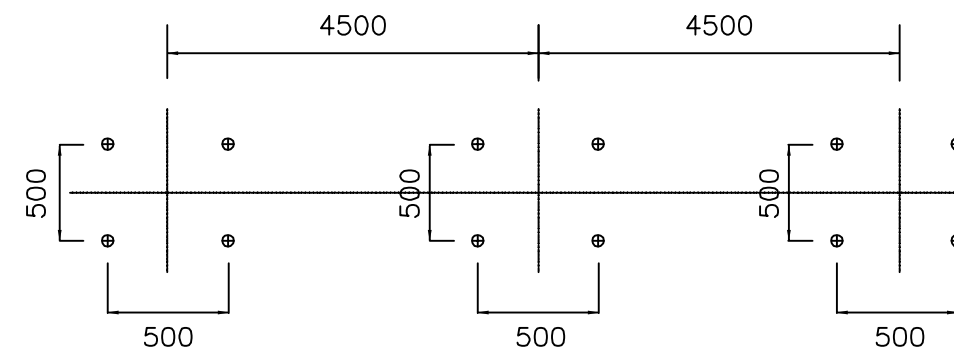
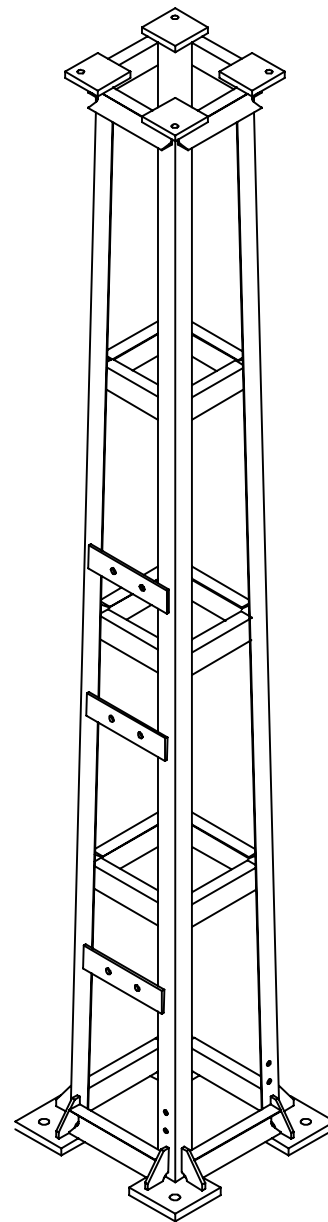
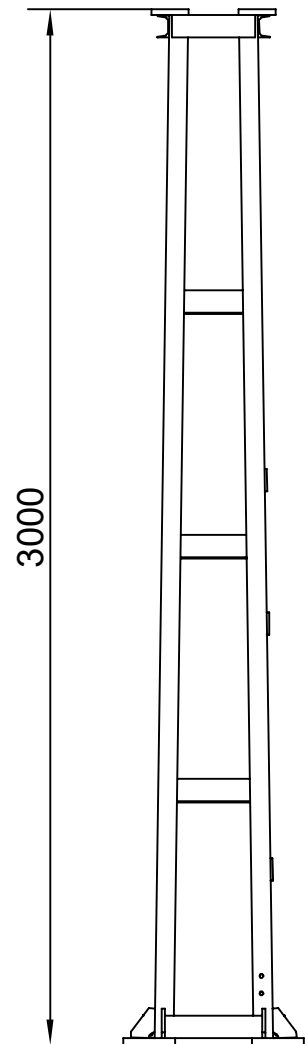
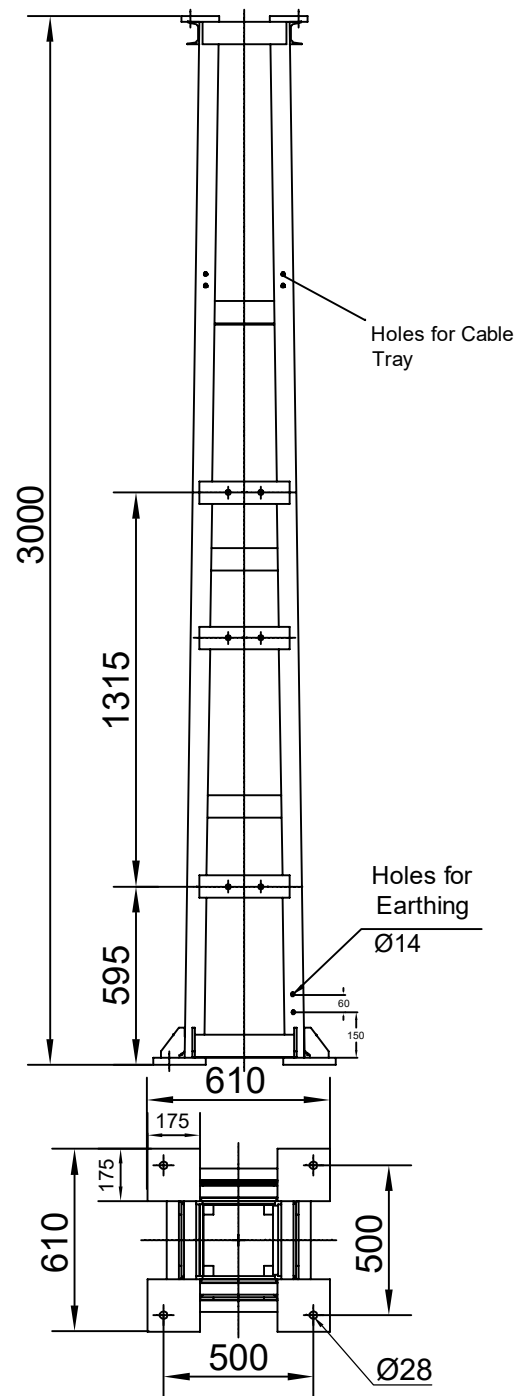

**FOUNDATION PLAN FOR 220KV CB**

Drawing approval subject to valid vendor registration

**CHIEF ENGINEER/PROJECTS  
APTRANSCO/VS/VIJAYAWADA**

- Remarks:
- 1) All dimensions are in mm.
  - 2) All structural steel shall conform to IS:2062
  - 3) Hot dip galvanizing acc. to ISO 1461 (thickness min.86µm average-25mm/kV)
  - 4) Hot dip galvanizing acc. to ISO 1461 (thickness min.120µm average-31mm/kV)
  - 5) All welding shall be done as per IS:816.
  - 6) Faces joined by welding on top and bottom side should be grind.

HO/ESD-Coord/9E 03-90

Date	09.05.2023	CLIENT: Transmission Corporation of Andhra Pradesh Limited	SIEMENS AURANGABAD	Descr : 245kV,50kA,4000A SF6 CB.	SO No :	Qty:	1HG 594-03864-004
Prep	MSR	CONTRACTOR: As Applicable					
Ckd.	SB	PROJECT: As Applicable PO.NO.: As Applicable					
Issue	Remarks	Date Name	Original / Replacement for /Replaced by :-	Details : SUPPORT STRUCTURE	Drg. No:- (3)G71AHS-NA403-Z1503	Sh. 2 2 Sh.	

NOTE: 1. Drawings Approval subject to valid type test reports, to be checked during acceptance tests.  
 2. For EPC contractors only.

PSD Bypass Equipment (K0,K1 &S14) shall be supplied by respective EPC Contractor.

The reproduction, transmission or use of this document or its contents is not permitted without express written authority of the originator. All rights, including rights created by patent grant or registration of a utility model or design, are reserved.

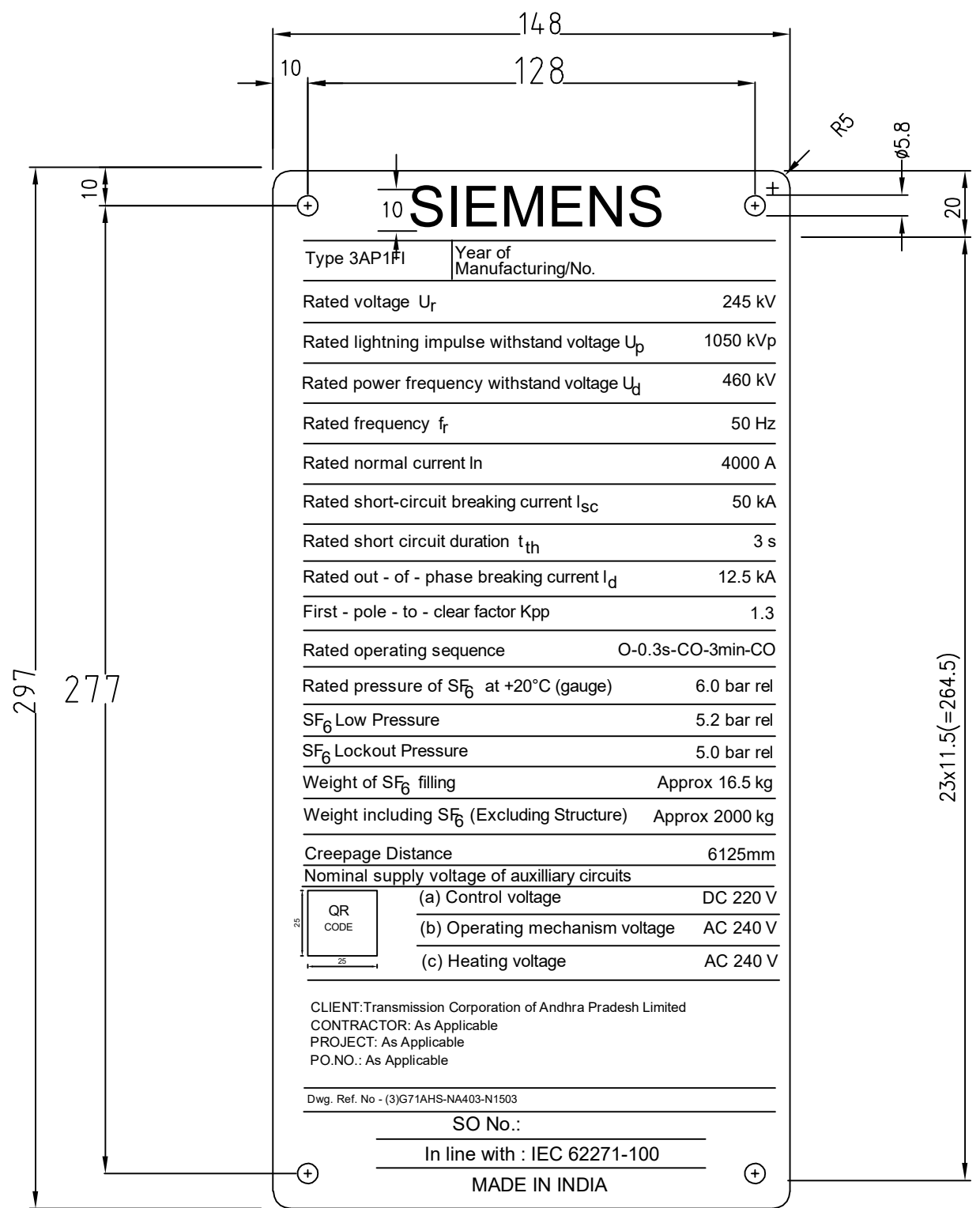

**CHIEF ENGINEER/PROJECTS  
 APTRANSCO/VS/VIJAYAWADA**

**Pole A**

CLIENT: Transmission Corporation of Andhra Pradesh Limited

Sr No -

**Pole B**

CLIENT: Transmission Corporation of Andhra Pradesh Limited

Sr No -

**Pole C**

CLIENT: Transmission Corporation of Andhra Pradesh Limited

Sr No -

Rating Plate on respective operating mechanism

PSD Bypass Equipment (K0,K1 &S14) shall be supplied by respective EPC Contractor.

1. Minimum 300mm plinth shall be maintained for CT/PT/CVT/Isolators/IV/LA/Breakers in the substation during foundation works to ensure safe live to ground clearance per IE rules.
2. Since the supply of terminal connectors is not in the scope of manufacturer as mentioned in the drawings. The EPC contractor shall be instructed to supply the same line with CT/PT/CVT/Isolator/IVT/LA/Breaker's requirement and compatibility.

NOTE :- NAME PLATE MADE UP OF ALUMINIUM COMPOSITE  
 LETTERS ARE IN WHITE COLOUR WITH BLACK BACKGROUND

H0/ESD-Coord/9E 03-90 TT

Date	09.05.2023	CLIENT: Transmission Corporation of Andhra Pradesh Limited	<b>SIEMENS</b> AURANGABAD	Descr :	245kV,50kA,4000A SF6 CB.	SO No :	Qty:	
Prep	MSR	CONTRACTOR: As Applicable		Type :	3AP1FI			
Ckd.	SB	PROJECT: As Applicable		Details :	NAME PLATE(25mm/kV)			
Issue	Remarks	Date	Name	Norm.	Original / Replacement for /Replaced by :-	Drg. No:- (3)G71AHS-NA403-N1503-		Sh. 1 2 Sh.



# OPERATING MECHANISM COMPARTMENT POLE LA, LB, LC

NOTE: 1. Drawings Approval subject to valid type test reports, to be checked during acceptance tests.  
2. For EPC contractors only.

The reproduction, transmission or use of this document or its contents is not permitted without express written authority of the copyright owner. All rights, including rights created by patent grant or registration of a utility model or design, are reserved.

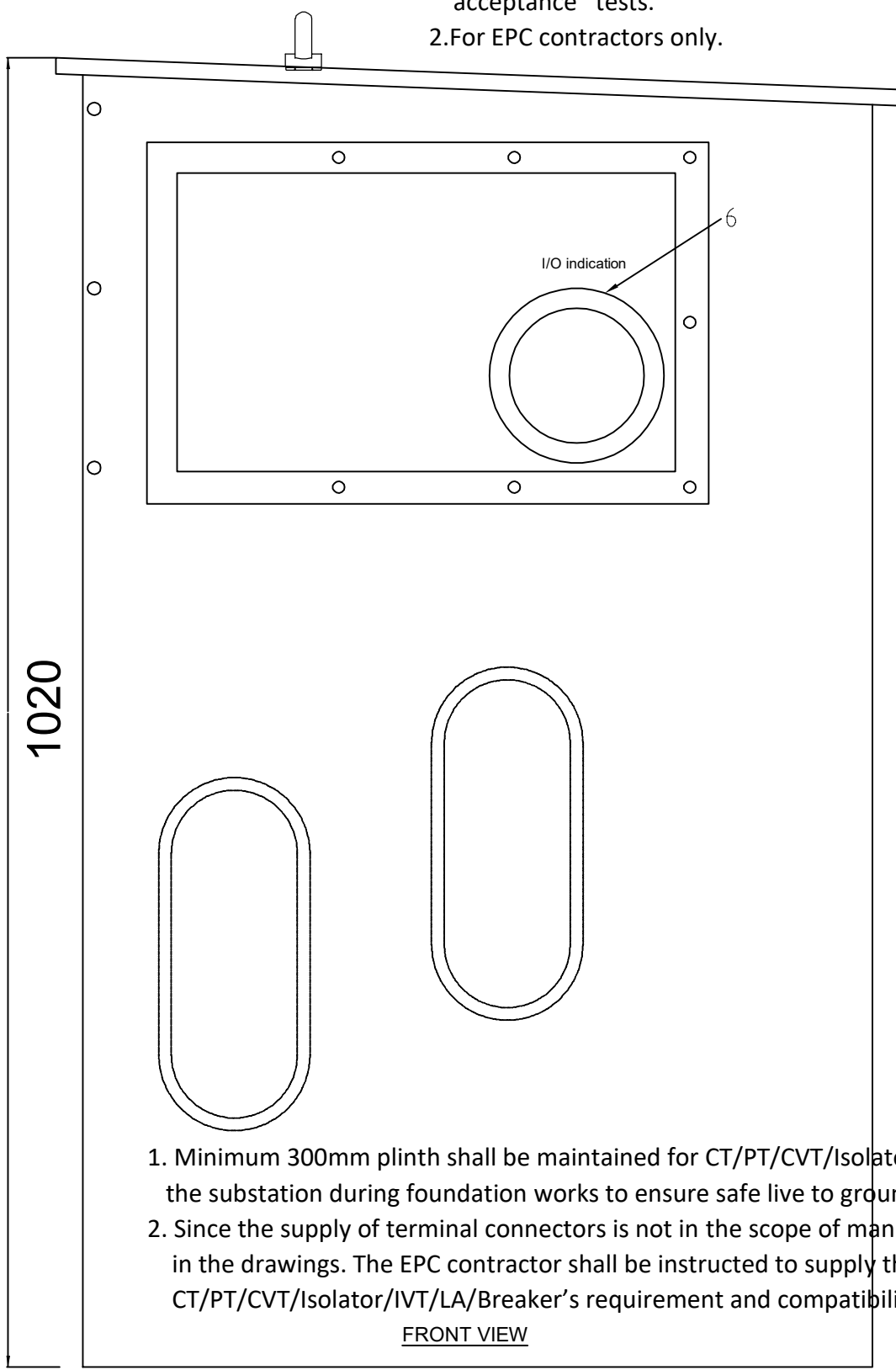

1. Minimum 300mm plinth shall be maintained for CT/PT/CVT/Isolators/IV/LA/Breakers in the substation during foundation works to ensure safe live to ground clearance per IE rules.
2. Since the supply of terminal connectors is not in the scope of manufacturer as mentioned in the drawings. The EPC contractor shall be instructed to supply the same line with CT/PT/CVT/Isolator/IVT/LA/Breaker's requirement and compatibility.

\*NOTE:  
1. POSITION OF EQUIPMENTS MAY CHANGE DURING DETAILED ENGINEERING.  
2. Degree of protection - IP55

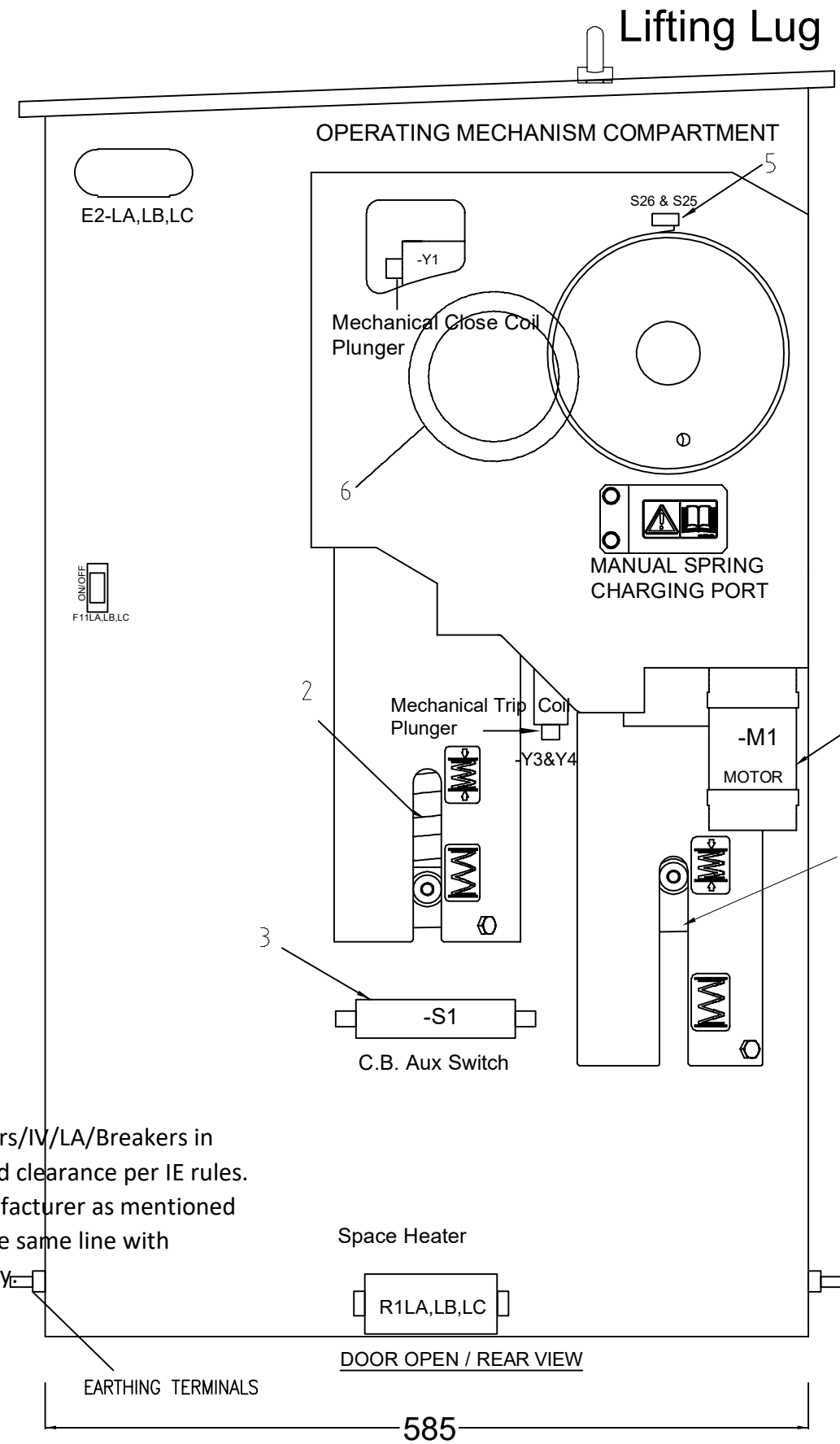

## Details of operating mechanism box

1.	Closing Spring
2.	Opening Spring
3.	Circuit breaker auxiliary switch
4.	Spring Charging Motor
5.	Limit Switch for motor
6.	Glass Window- CB ON/OFF

**CHIEF ENGINEER/PROJECTS  
APTRANSCO/VS/VIJAYAWADA**

HO/ESD-Coord/9E 03-90

Date	09.05.2023	CLIENT: Transmission Corporation of Andhra Pradesh Limited	<b>SIEMENS</b> AURANGABAD	Descr : 245kV, 50kA, 4000A SF6 CB. Type : 3AP1FI Details : CONTROL PANEL LAYOUT	SO No :	Qty:	Drg. No:- (3)G71AHS-NA403-L1503	Sh. 2 3 Sh.
Prep	MSR	CONTRACTOR: As Applicable						
Ckd.	SB	PROJECT: As Applicable PO.NO.: As Applicable						
Issue	Remarks	Date	Name	Norm.	Original / Replacement for / Replaced by :-			

**INTER POLE CABLING LAYOUT**

The reproduction, transmission or use of this document or its contents is not permitted without express written authority of the authority. All rights, including rights created by patent grant or registration of a utility model or design, are reserved.

A

B

C

D

E

F

A

E

C

F

E

F

**OPERATING MECHANISM COMPARTMENT POLE LA**

**OPERATING MECHANISM COMPARTMENT POLE LB**

**OPERATING MECHANISM COMPARTMENT POLE LC**

**CHIEF ENGINEER/PROJECTS  
APTRANSCO/VISVIJAYAWADA**

NOTE: 1. Drawings Approval subject to valid type test reports, to be checked during acceptance tests.  
2. For EPC contractors only.

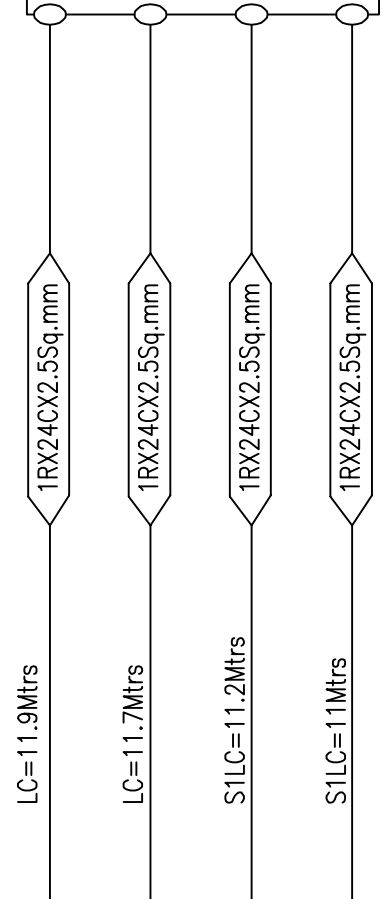
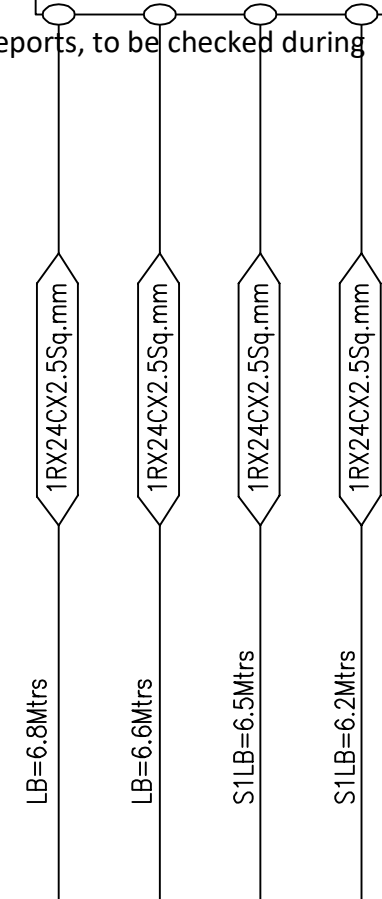
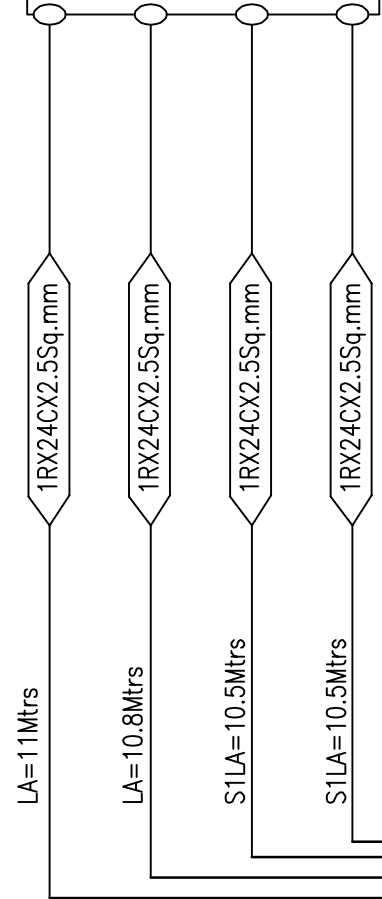
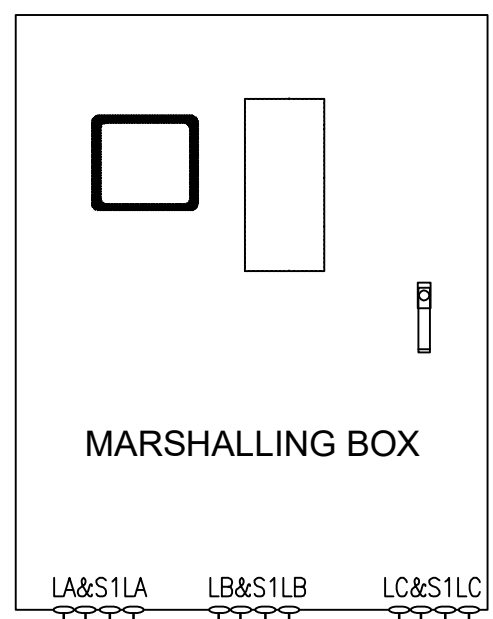

→(Armoured)

→(Armoured)

→(Armoured)

Legened: 1RX24CX2.5Sq.mm  
→Cores  
→Runs

Drawing approval subject to valid vendor registration

NOTE: INTERPOLE CONNECTION BETWEEN POLE PANEL TO MARSHALLING BOX TO BE DONE AT SITE & SUPPLY OF INTERPOLE CABLE IS IN SIEMENS SCOPE  
Interpole cable - Armoured, 2.5 sq mm 24 core 4nos for AC/DC current

Date	09.05.2023	CLIENT: Transmission Corporation of Andhra Pradesh Limited	<b>Siemens Ltd.</b> AURANGABAD	Descr :	245kV, 50kA, 4000A SF6 CB.	SO No :	Qty:
Prep	MSR	CONTRACTOR: As Applicable		Type :	3AP1FI		
Ckd.	SB	PROJECT: As Applicable		Details :	INTERPOLE_CABLE_DETAILS		
Issue	Remarks	Date	Name	Norm.	Original/Replacement For/Replaced by :-	Drg. No:- (3)G71AHS-NA403-L1503	

Sh. 3  
3 Sh.

NOTE: 1. Drawings Approval subject to valid type test reports, to be checked during acceptance tests.  
2.For EPC contractors only.

1. Minimum 300mm plinth shall be maintained for CT/PT/CVT/Isolators/IV/LA/Breakers in the substation during foundation works to ensure safe live to ground clearance per IE rules.
2. Since the supply of terminal connectors is not in the scope of manufacturer as mentioned in the drawings. The EPC contractor shall be instructed to supply the same line with CT/PT/CVT/Isolator/IVT/LA/Breaker's requirement and compatibility.

**NOTES :-**

1. ALL AUXILLIARY CONTACTS SHOWN WITH CIRCUIT DE-ENERGISED.
2. ALL CONTACTS OF DENSITY MONITOR SHOWN WITH THE LOW PRESSURE CONDITION.
3. CONTACTS OF LIMIT SWITCH OF SPRING CHARGING MOTOR SHOWN WITH SPRING DISCHARGED.
4. MANUFACTURING TOLERANCE APPLICABLE, EQUIPMENT POSITION MAY CHANGE DURING MANUFACTURING.
5. WIRING IN THE DOTTED LINES INDICATE THE WIRING CIRCUIT INSIDE THE CONTROL CUBICLE (LA,LB,LC)
6. INTERPOLE CONNECTION BETWEEN POLE PANEL TO MARSHALLING BOX TO BE DONE AT SITE & SUPPLY OF INTERPOLE CABLE IS IN SIEMENS SCOPE
7. PAGES 2 TO 9 WITH LAMINATED SHALL BE KEPT INSIDE THE MAR.BOX.

THE REPRODUCTION, TRANSMISSION OR USE OF THIS DOCUMENT OR ITS CONTENTS IS NOT PERMITTED UNLESS THE REPRODUCER IS NOTIFIED BY THE COPYRIGHT OWNER. ALL RIGHTS, INCLUDING RIGHTS CREATED BY WITHOUT EXPRESS WRITTEN AUTHORITY, PATENT GRANT OR REGISTRATION OF A UTILITY MODEL OR DESIGN, ARE RESERVED.

**CHIEF ENGINEER/PROJECTS  
APTRANSCO/VS/VIJAYAWADA**

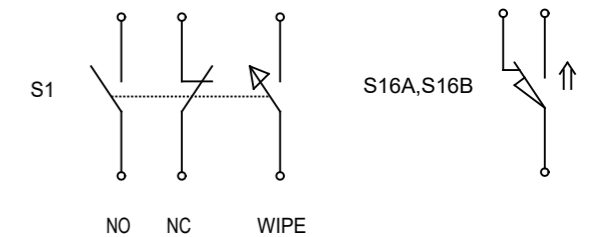

CONTACT GEOMETRY OF S1 AND S16A, S16B SWITCH

Date		09.05.2023		CLIENT: Transmission Corporation of Andhra Pradesh Limited		<b>SIEMENS LTD.</b>		Descp:245KV,50KA,4000A		SO NO:		Qty:		=ZZA	
Prep.		MSR		CONTRACTOR:As applicable		Aurangabad		Type:3AP1FI						++	
Ckd.		SB		PROJECT: As Applicable				Dwg. Name:Schematic drawing						Sh. 1	
Issue		Remarks		Date		Name		ORIGINAL/REPLACEMENT FOR/REPLACED BY:		Drg No: (3)G71AHS-NA403-W1503		9		Sh.	

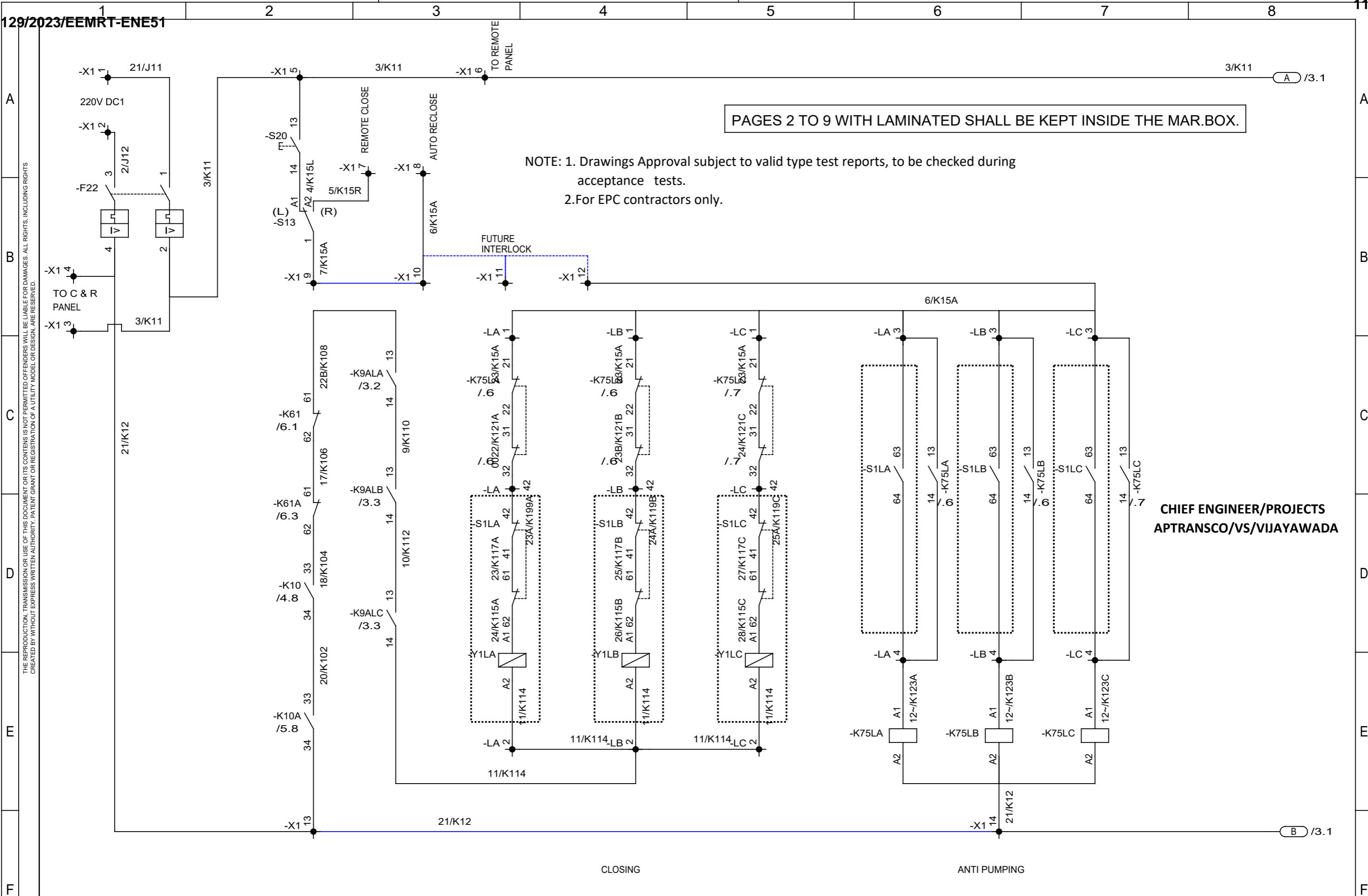

THE REPRODUCTION, TRANSMISSION OR USE OF THIS DOCUMENT OR ITS CONTENTS IS NOT PERMITTED OFFENDERS WILL BE LIABLE FOR DAMAGES. ALL RIGHTS, INCLUDING RIGHTS CREATED BY WITHOUT EXPRESS WRITTEN AUTHORITY, PATENT GRANT OR REGISTRATION OF A UTILITY MODEL OR DESIGN, ARE RESERVED.

**CHIEF ENGINEER/PROJECTS  
APTRANSCO/VISVIJAYAWADA**

Date		09.05.2023		CLIENT: Transmission Corporation of Andhra Pradesh Limited		SIEMENS LTD.		Descp:245KV,50KA,4000A		SO NO:		Qty:		=ZZA	
Prep.		MSR		CONTRACTOR: As applicable		Aurangabad		Type:3AP1FI						++	
Ckd.		SB		PROJECT: As Applicable				Dwg. Name:Schematic drawing						Sh. 2	
Issue				PO.NO.: As applicable								Drg No: (3)G71AHS-NA403-W1503		9 Sh.	
				ORIGINAL/REPLACEMENT FOR/REPLACED BY:											

NOTE: 1. Drawings Approval subject to valid type test reports, to be checked during acceptance tests.  
 2.For EPC contractors only.

PAGES 2 TO 9 WITH LAMINATED SHALL BE KEPT INSIDE THE MAR.BOX.

A  
B  
C  
D  
E  
F

A  
B  
C  
D  
E  
F

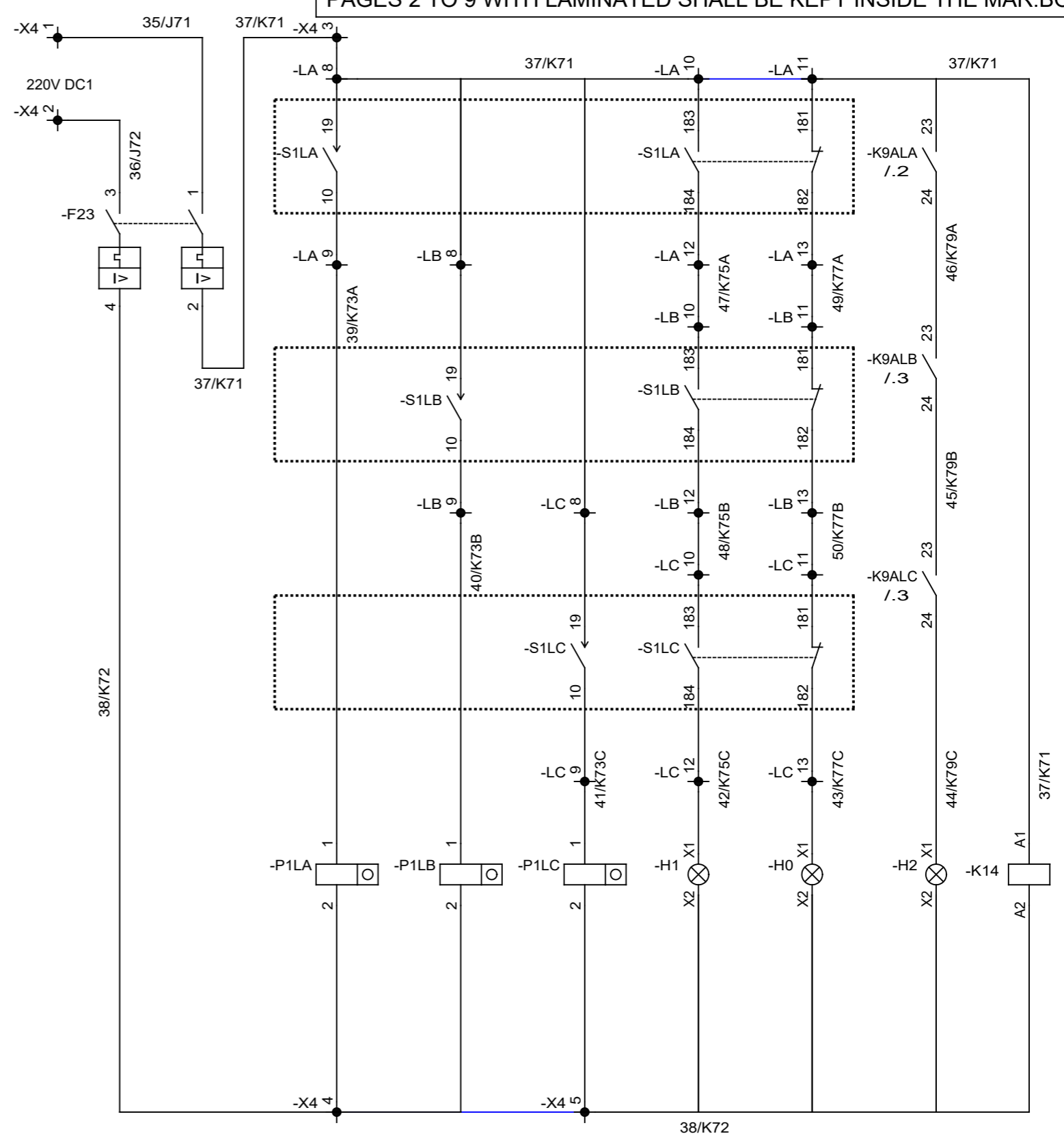
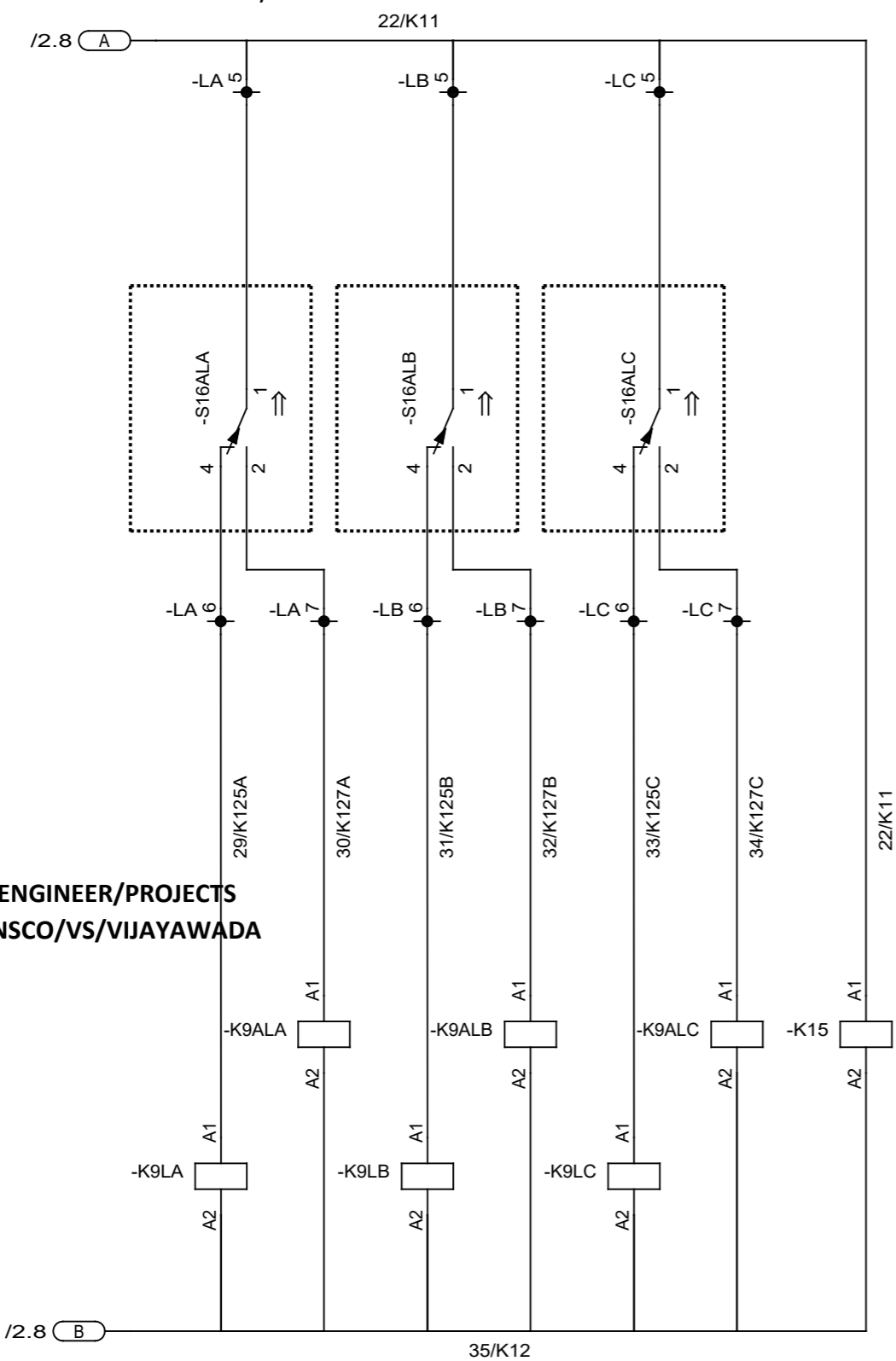

**CHIEF ENGINEER/PROJECTS**  
**APTRANSCO/VISVIJAYAWADA**

MOTOR CONTROL      MOTOR CONTROL      MOTOR CONTROL      CLOSING CKT SPRING CHARGE SUPPLY MONITOR

SPRING CHARGED STATUS      SPRING CHARGED STATUS      SPRING CHARGED STATUS      SPRING CHARGED STATUS

OPERATIONAL COUNTER POLE A      OPERATIONAL COUNTER POLE B      OPERATIONAL COUNTER POLE C      CB ON      CB OFF      SPRING CHARGED INDICATION      INDICATION SUPPLY MONITOR

Date: 09.05.2023		CLIENT: Transmission Corporation of Andhra Pradesh Limited		SIEMENS LTD.		Descp:245KV,50KA,4000A		SO NO:		Qty:		=ZZA	
Prep: MSR		CONTRACTOR: As applicable		Aurangabad		Type:3AP1FI						++	
Ckd: SB		PROJECT: As applicable				Dwg. Name:Schematic drawing						Sh. 3	
Issue		Remarks		Date		Name		ORIGINAL/REPLACEMENT FOR/REPLACED BY:		Drg No: (3)G71AHS-NA403-W1503		9 Sh.	

THE REPRODUCTION, TRANSMISSION OR USE OF THIS DOCUMENT OR ITS CONTENTS IS NOT PERMITTED UNLESS THE REPRODUCER IS NOTIFIED BY THE COPYRIGHT OWNER. ALL RIGHTS, INCLUDING RIGHTS CREATED BY WITHOUT EXPRESS WRITTEN AUTHORITY, PATENT GRANT OR REGISTRATION OF A UTILITY MODEL OR DESIGN, ARE RESERVED.



NOTE: 1. Drawings Approval subject to valid type test reports, to be checked during acceptance tests.  
2. For EPC contractors only.

PAGES 2 TO 9 WITH LAMINATED SHALL BE KEPT INSIDE THE MAR.BOX.

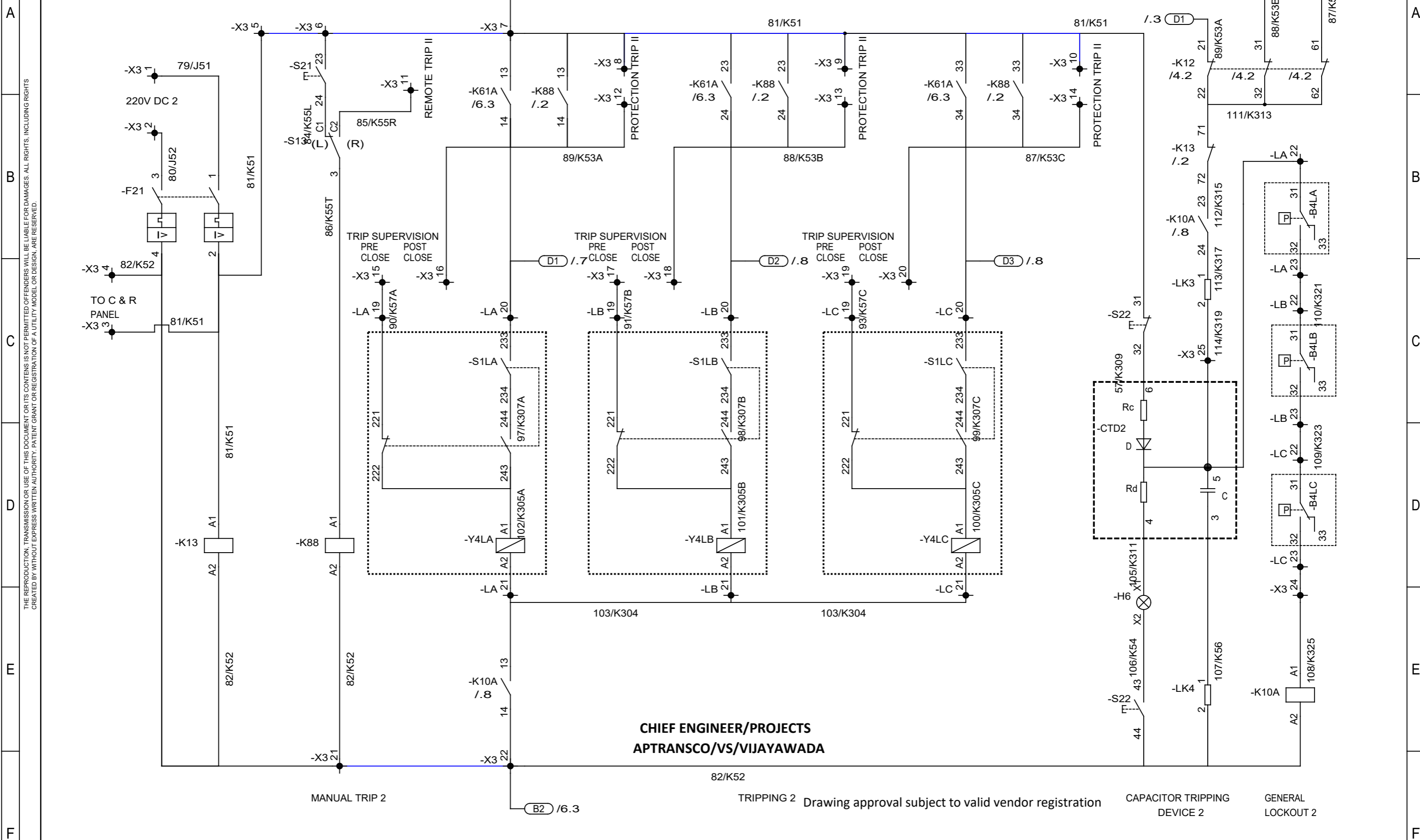

CHIEF ENGINEER/PROJECTS  
APTRANSCO/VS/VIJAYAWADA

82/K52 MANUAL TRIP 2  
82/K52 TRIPPING 2 Drawing approval subject to valid vendor registration  
57/K309 CAPACITOR TRIPPING DEVICE 2  
109/K323 GENERAL LOCKOUT 2

Date: 09.05.2023		CLIENT: Transmission Corporation of Andhra Pradesh Limited		SIEMENS LTD.		Descp: 245KV, 50KA, 4000A		SO NO: Qty: =ZZA	
Prep: MSR		CONTRACTOR: As applicable		Aurangabad		Type: 3AP1FI		++	
Ckd: SB		PROJECT: As applicable		ORIGINAL/REPLACEMENT FOR/REPLACED BY:		Dwg. Name: Schematic drawing		Sh. 5	
Issue		Remarks		Date		Name		Sh. 9	
Date		Name		Date		Name		Sh. 9	

PAGES 2 TO 9 WITH LAMINATED SHALL BE KEPT INSIDE THE MAR.BOX.

Drawing approval subject to valid vendor registration

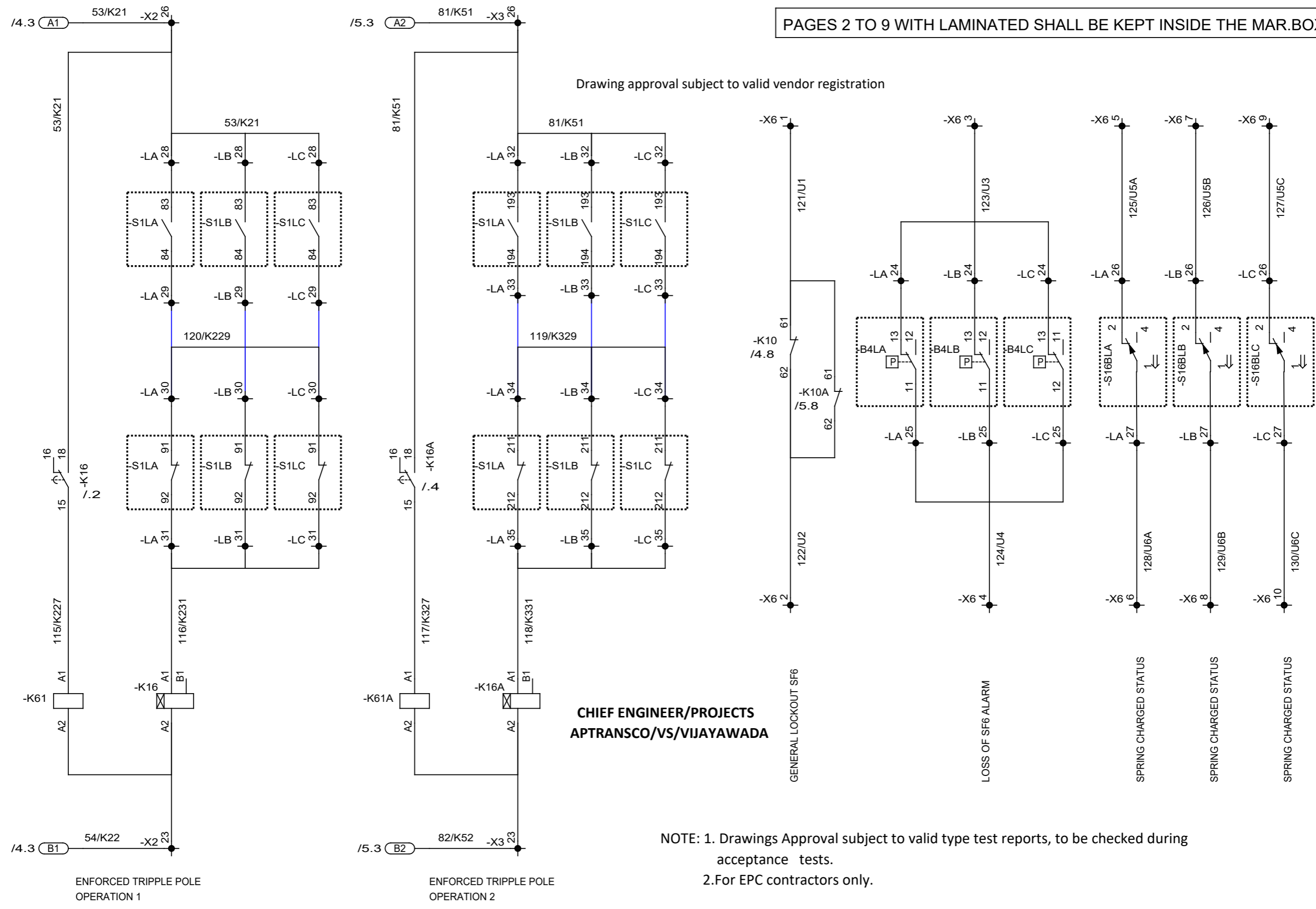

CHIEF ENGINEER/PROJECTS  
APTRANSCO/VISVIJAYAWADA

NOTE: 1. Drawings Approval subject to valid type test reports, to be checked during acceptance tests.  
2. For EPC contractors only.

ENFORCED TRIPPLE POLE OPERATION 1

ENFORCED TRIPPLE POLE OPERATION 2

THE REPRODUCTION, TRANSMISSION OR USE OF THIS DOCUMENT OR ITS CONTENTS IS NOT PERMITTED UNLESS THE REPRODUCER IS A UTILITY MODEL OR DESIGN, ARE RESERVED.

Date		09.05.2023		CLIENT: Transmission Corporation of Andhra Pradesh Limited		SIEMENS LTD.		Descp:245KV,50KA,4000A		SO NO:		Qty:		=ZZA	
Prep.		MSR		CONTRACTOR: As applicable		Aurangabad		Type:3AP1FI						++	
Ckd.		SB		PROJECT: As applicable				Dwg. Name:Schematic drawing						Sh. 6	
Issue		Remarks		Date		Name		ORIGINAL/REPLACEMENT FOR/REPLACED BY:		Drg No: (3)G71AHS-NA403-W1503				9 Sh.	

NOTE: 1. Drawings Approval subject to valid type test reports, to be checked during acceptance tests.  
 2.For EPC contractors only.

PAGES 2 TO 9 WITH LAMINATED SHALL BE KEPT INSIDE THE MAR.BOX.

Drawing approval subject to valid vendor registration

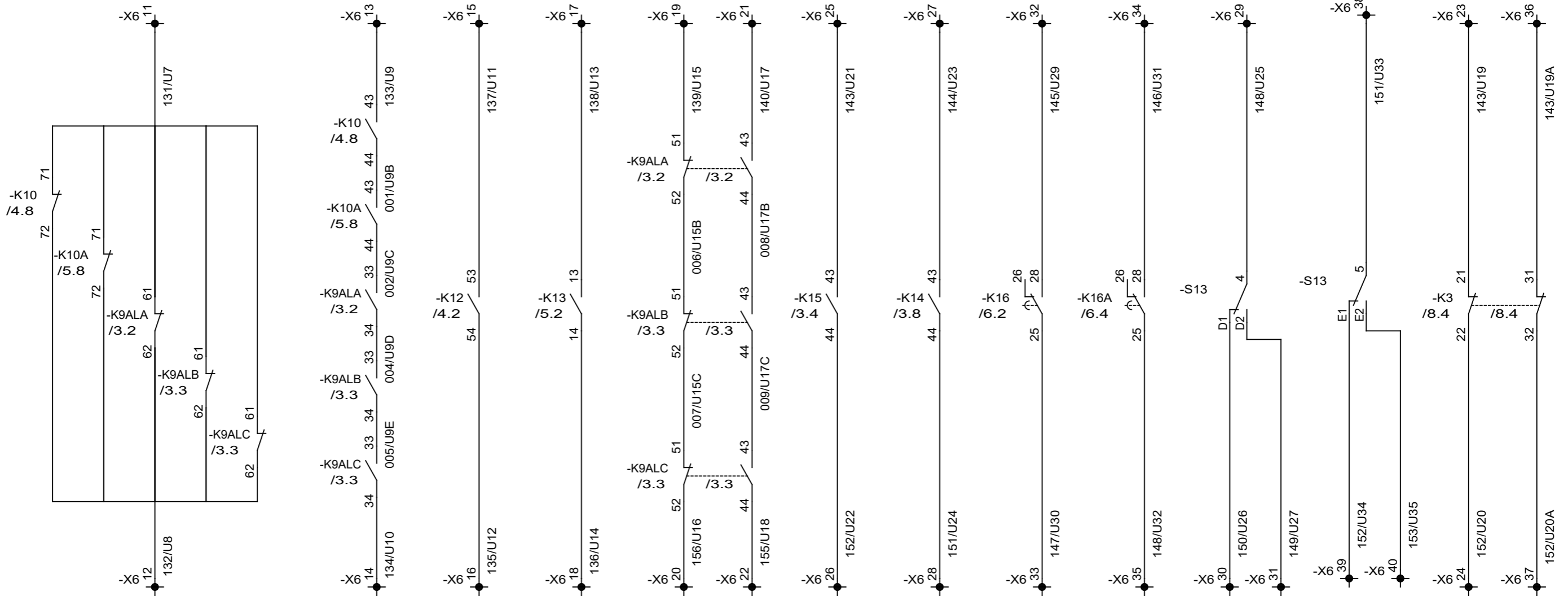

CONDITIONS TO BE VERIFIED FOR AUTO RECLOSER AUTO RECLOSE I

CONDITIONS TO BE VERIFIED FOR AUTO RECLOSER AUTO RECLOSE II

DC SUPPLY 1 MONITORING

DC SUPPLY 2 MONITORING

SPRING STATUS SUPERVISORY SYSTEM

CLOSING, SPRING CHARGE SUPPLY MONITORING

INDICATION SUPPLY MONITORING

POLE DISCREPANCY ALARM 1

POLE DISCREPANCY ALARM 2

CB STATUS LOCAL

CB STATUS REMOTE

CB STATUS LOCAL

CB STATUS REMOTE

AC SUPPLY SUPERVISION

- Minimum 300mm plinth shall be maintained for CT/PT/CVT/Isolators/IV/LA/Breakers in the substation during foundation works to ensure safe live to ground clearance per IE rules.
- Since the supply of terminal connectors is not in the scope of manufacturer as mentioned in the drawings. The EPC contractor shall be instructed to supply the same line with CT/PT/CVT/Isolator/IVT/LA/Breaker's requirement and compatibility.

CHIEF ENGINEER/PROJECTS  
 APTRANSCO/VISVIJAYAWADA

Date	09.05.2023	CLIENT: Transmission Corporation of Andhra Pradesh Limited	SIEMENS LTD. Aurangabad	Descp:245KV,50KA,4000A Type:3AP1FI Dwg. Name:Schematic drawing	SO NO:	Qty:	=ZZA ++
Prep.	MSR	CONTRACTOR:As applicable PROJECT: As Applicable PO.NO.: As applicable					
Ckd.	SB						
Issue	Remarks	Date	Name	ORIGINAL/REPLACEMENT FOR/REPLACED BY:	Drg No: (3)G71AHS-NA403-W1503	Sh.	7
						9	Sh.

THE REPRODUCTION, TRANSMISSION OR USE OF THIS DOCUMENT OR ITS CONTENTS IS NOT PERMITTED OFFENDERS WILL BE LIABLE FOR DAMAGES. ALL RIGHTS, INCLUDING RIGHTS CREATED BY WITHOUT EXPRESS WRITTEN AUTHORITY, PATENT GRANT OR REGISTRATION OF A UTILITY, MODEL OR DESIGN, ARE RESERVED.

NOTE: 1. Drawings Approval subject to valid type test reports to be checked during acceptance tests.  
2. For EPC contractors only.

PAGES 2 TO 9 WITH LAMINATED SHALL BE KEPT INSIDE THE MAR.BOX.

3 Ph, 415 V AC

THE REPRODUCTION, TRANSMISSION OR USE OF THIS DOCUMENT OR ITS CONTENTS IS NOT PERMITTED UNLESS THE REPRODUCER IS NOTIFIED BY THE ORIGINAL AUTHOR. ALL RIGHTS, INCLUDING RIGHTS CREATED BY WITHOUT EXPRESS WRITTEN AUTHORITY, PATENT GRANT OR REGISTRATION OF A UTILITY MODEL OR DESIGN, ARE RESERVED.

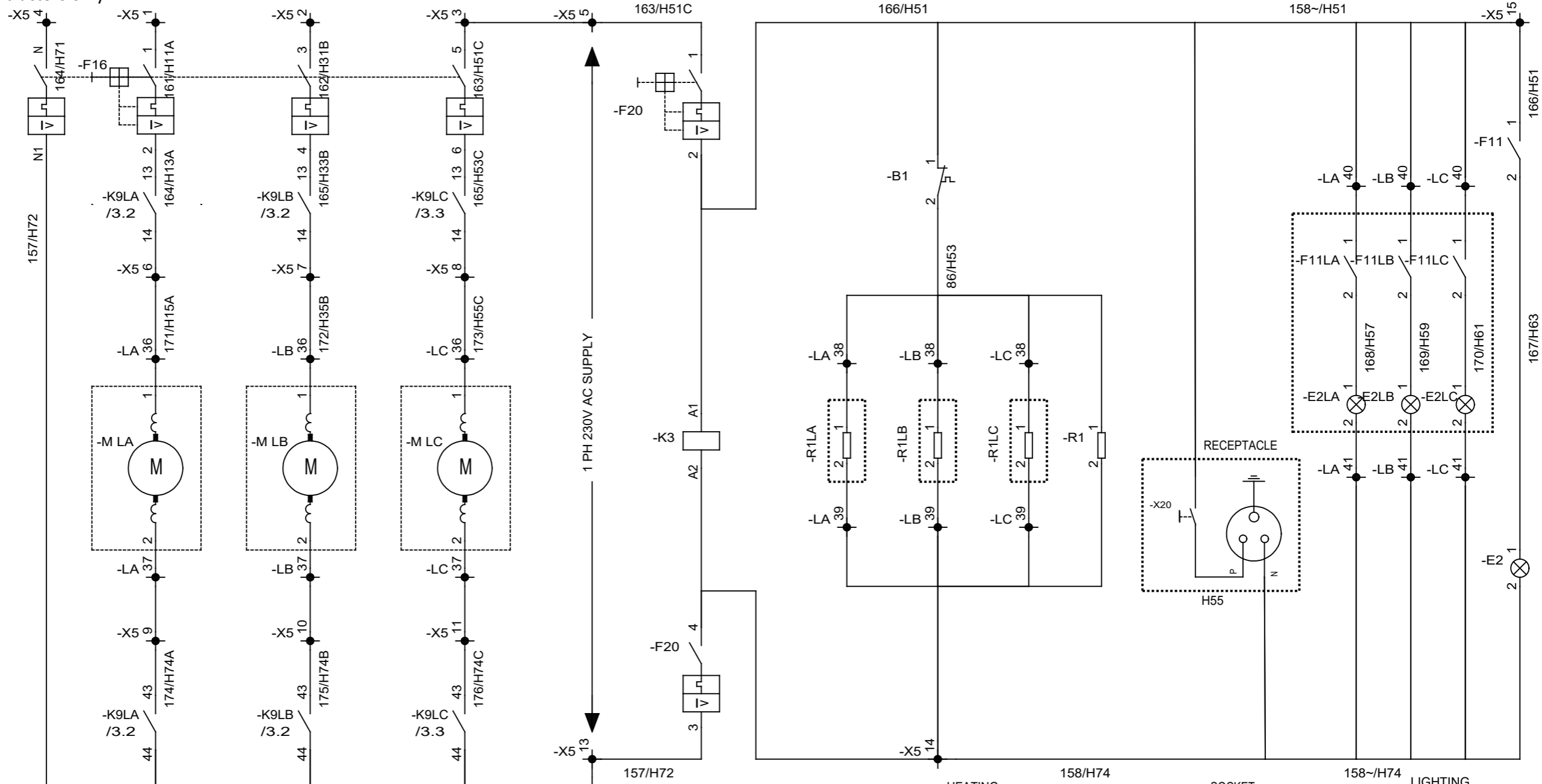

1. Minimum 300mm plinth shall be maintained for CT/PT/CVT/Isolators/IV/LA/Breakers in the substation during foundation works to ensure safe live to ground clearance per IE rules.
2. Since the supply of terminal connectors is not in the scope of manufacturer as mentioned in the drawings. The EPC contractor shall be instructed to supply the same line with CT/PT/CVT/Isolator/IVT/LA/Breaker's requirement and compatibility.

MOTOR CIRCUIT

HEATING

SOCKET

158~/H74 LIGHTING

UTILITY CIRCUIT

PRESSURE TRANSDUCER CIRCUIT

**CHIEF ENGINEER/PROJECTS**  
**APTRANSCO/VS/VIJAYAWADA**

Date	09.05.2023	CLIENT: Transmission Corporation of Andhra Pradesh Limited
Prep.	MSR	CONTRACTOR: As applicable
Ckd.	SB	PROJECT: As applicable
Issue		PO.NO.: As applicable
Remarks		ORIGINAL/REPLACEMENT FOR/REPLACED BY:
		SIEMENS LTD. Descp:245KV,50KA,4000A
		Aurangabad Type:3AP1FI
		Dwg. Name:Schematic drawing
		SO NO: Qty: =ZZA
		++
		Drg No: (3)G71AHS-NA403-W1503
		Sh. 8
		9 Sh.

PAGES 2 TO 9 WITH LAMINATED SHALL BE KEPT INSIDE THE MAR.BOX.

2.For EPC contractors only.

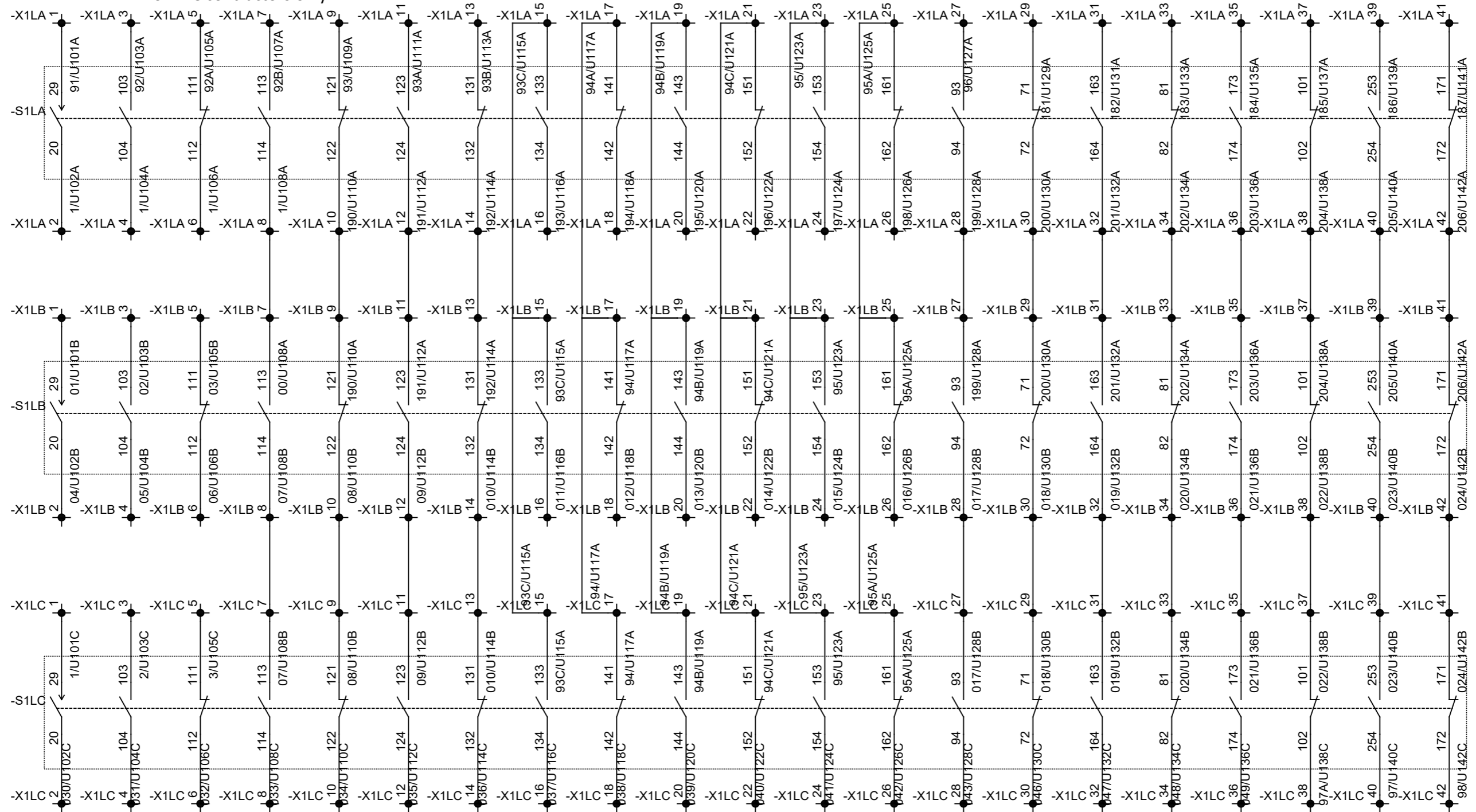

CHIEF ENGINEER/PROJECTS  
APTRANSCO/VISVIJAYAWADA

10NO + 10NC + 1Wi SPARE CONTACTS OF CB AUXILIARY SWITCH

1. Minimum 300mm plinth shall be maintained for CT/PT/CVT/Isolators/IV/LA/Breakers in the substation during foundation works to ensure safe live to ground clearance per IE rules.
2. Since the supply of terminal connectors is not in the scope of manufacturer as mentioned in the drawings. The EPC contractor shall be instructed to supply the same line with CT/PT/CVT/Isolator/IVT/LA/Breaker's requirement and compatibility.

Date	09.05.2023	CLIENT: Transmission Corporation of Andhra Pradesh Limited	SIEMENS LTD. Aurangabad	Descp:245KV,50KA,4000A Type:3AP1FI Dwg. Name:Schematic drawing	SO NO:	Qty:	=ZZA ++
Prep.	MSR	CONTRACTOR:As applicable					
Ckd.	SB	PROJECT: As applicable PO.NO.: As applicable					
Issue	Remarks	Date	Name	ORIGINAL/REPLACEMENT FOR/REPLACED BY:	Drg No: (3)G71AHS-NA403-W1503		Sh. 9
							9 Sh.

THE REPRODUCTION, TRANSMISSION OR USE OF THIS DOCUMENT OR ITS CONTENTS IS NOT PERMITTED UNLESS THE REPRODUCER HAS OBTAINED THE NECESSARY PERMISSION FROM THE ORIGINAL AUTHOR. ALL RIGHTS, INCLUDING RIGHTS CREATED BY WITHOUT EXPRESS WRITTEN AUTHORITY, PATENT GRANT OR REGISTRATION OF A UTILITY MODEL OR DESIGN, ARE RESERVED.

A

B

C

D

E

F

A

B

C

D

E

F

THE REPRODUCTION, TRANSMISSION OR USE OF THIS DOCUMENT OR ITS CONTENTS IS NOT PERMITTED UNLESS THE OFFENDERS WILL BE LIABLE FOR DAMAGES. ALL RIGHTS, INCLUDING RIGHTS CREATED BY WITHOUT EXPRESS WRITTEN AUTHORITY, PATENT GRANT OR REGISTRATION OF A UTILITY MODEL OR DESIGN, ARE RESERVED.

1	2	3	4	5	6	7	8	
CABLE DESTINATION	TYPE, CORE NO., CROSS SECTION	DEST./ITEM DES.	LEVEL	A C D B O O O O		TERMINAL	LINE-UP TERMINAL TYPE	TYPE OF WIRING
1							41xSTH3	1) EQUIPMENT WIRING
2								
3								
4								
5								
6								
7								
8								
9								
10								

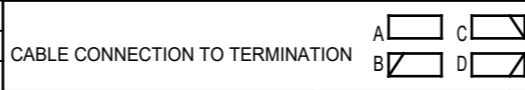

										TERMINATION A/C DESTINATION/ITEM DESIGNATION	TERMINAL STRIP -LA			TYPE	TERMINATION B/D DESTINATION/ITEM DESIGNATION					
1	2	3	4	5	6	7	8	9	10				LINK	NO.						
										K15A	-LB	1	A	O		1	STH3	K15A	-K75LA	21
										K114	-Y1LA	A2		O		2	STH3	K114	-LB	2 A
										K15A	-LC	1	A	O		3	STH3	K15A	-S1LA	63
											-LB	3						K15A	-K75LA	13
										K125	-S1LA	64		O		4	STH3	K123A	-K75LA	A1
																		K125	-K75LA	14
										K11	-LB	5	A	O		5	STH3	K11	-S16ALA	1
											-X1	6								
										K131A	-S16ALA	4		O		6	STH3	K125A	-K9LA	A1
										K133A	-S16ALA	2		O		7	STH3	K127A	-K9ALA	A1
										K71	-X4	3	B	O		8	STH3	K71	-S1LA	19
																		K71	-LB	8 A
										K73A	-S1LA	10		O		9	STH3	K73A	-P1LA	1
										K71	-S1LA	183		O		10	STH3	K71	-LC	8 A
										K71	-S1LA	181		O		11	STH3	K71	-K9ALA	23
										K75A	-S1LA	184		O		12	STH3	K75A	-LB	10 A
										K77A	-S1LA	182		O		13	STH3	K77A	-LB	11 A
										K27A	-X2	15	A	O		14	STH3	K27A	-S1LA	191
										K23A	-K13	21		O		15	STH3	K23A	-S1LA	203
											-K61	14								
										K204	-Y3LA	A2		O		16	STH3	K204	-K10	13
																		K204	-LB	16 B
										K219	-CTD1	5		O		17	STH3	K219	-B4LA	21
										K221	-B4LA	22		O		18	STH3	K221	-LB	17 A
										K57A	-X3	15	A	O		19	STH3	K57A	-S1LA	221
										K53A	-K12	21		O		20	STH3	K53A	-S1LA	233
											-K61A	14								
										K304	-Y4LA	A2		O		21	STH3	K304	-K10A	13
																		K304	-LB	21 B
										K319	-CTD2	5		O		22	STH3	K319	-B4LA	31
										K321	-B4LA	32		O		23	STH3	K321	-LB	22 A
											-LB	24	A	O		24	STH3		-B4LA	13
											-B4LA	11		O		25	STH3		-LB	25 B
										U5A	-X6	5	A	O		26	STH3	U5A	-S16BLA	2
										U6A	-S16BLA	1		O		27	STH3	U6A	-X6	6 A
										K21	-LB	28	A	O		28	STH3	K21	-S1LA	83
											-X2	26								
										K229	-S1LA	84		O		29	STH3			
										K229	-LB	30	A	O		30	STH3	K229	-S1LA	91



Date	09.05.2023	CLIENT:	Transmission Corporation of Andhra Pradesh Limited	SIEMENS LTD.	Descp:	245KV,50KA,4000A	SO NO:		Qty:		=ZZA
Prep.	MSR	CONTRACTOR:	As applicable	Aurangabad	Type:	3AP1FI					++
Ckd.	SB	PROJECT:	As applicable		Dwg. Name:	Terminal Plan					Sh. 1
Issue		PO.NO.:	As applicable								18 Sh.
Remarks		ORIGINAL/REPLACEMENT FOR/REPLACED BY:									
Date											
Name											
Drg No: (3)G71AHS-NA403-T1503											



1	2	3	4	5	6	7	8
1							
2							
3							
4							
5							
6							
7							
8							
9							
10							

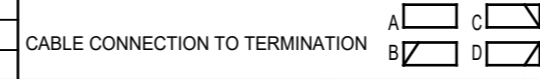
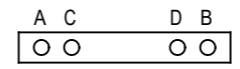

										TERMINATION A/C DESTINATION/ITEM DESIGNATION			TERMINAL STRIP -LB			TYPE	TERMINATION B/D DESTINATION/ITEM DESIGNATION				
1	2	3	4	5	6	7	8	9	10				LINK	NO.							
										K15A	-LA	1	A	○		1	STH3	K15A	-K75LB	21	
											-LC	1									
										K114	-Y1LB	A2		○		2	STH3	K114	-LC	2	B
											-LA	2						K114	-K9ALC	14	
										K15A	-LA	3	A	○		3	STH3	K15A	-S1LB	63	
											-LC	3						K15A	-K75LB	13	
										K125	-S1LB	64		○		4	STH3	K123B	-K75LB	A1	
																		K125	-K75LB	14	
										K11	-LA	5	A	○		5	STH3	K11	-S16ALB	1	
											-LC	5									
										K131B	-S16ALB	4		○		6	STH3	K125B	-K9LB	A1	
										K133B	-S16ALB	2		○		7	STH3	K127B	-K9ALB	A1	
										K71	-LA	8	B	○		8	STH3	K71	-S1LB	19	
											-LC	8									
										K73B	-S1LB	10		○		9	STH3	K73B	-P1LB	1	
										K75A	-LA	12	B	○		10	STH3	K75A	-S1LB	183	
										K77A	-LA	13	B	○		11	STH3	K77A	-S1LB	181	
										K75B	-S1LB	184		○		12	STH3	K75B	-LC	10	A
										K77B	-S1LB	182		○		13	STH3	K77B	-LC	11	A
										K27B	-S1LB	191		○		14	STH3	K27B	-X2	17	A
										K23B	-K13	31		○		15	STH3	K23B	-S1LB	203	
											-K61	24									
										K204	-Y3LB	A2		○		16	STH3	K204	-LA	16	B
																		K204	-LC	16	B
										K221	-LA	18	B	○		17	STH3	K221	-B4LB	21	
										K223	-B4LB	22		○		18	STH3	K223	-LC	17	A
										K57B	-S1LB	221		○		19	STH3	K57B	-X3	17	A
										K53B	-K12	31		○		20	STH3	K53B	-S1LB	233	
											-K61A	24									
										K304	-Y4LB	A2		○		21	STH3	K304	-LA	21	B
																		K304	-LC	21	B
										K321	-LA	23	B	○		22	STH3	K321	-B4LB	31	
										K323	-B4LB	32		○		23	STH3	K323	-LC	22	A
											-LA	24	A	○		24	STH3		-B4LB	13	
											-B4LB	11		○		25	STH3		-LA	25	B
										U5B	-X6	7	A	○		26	STH3	U5B	-S16BLB	2	
										U6B	-S16BLB	1		○		27	STH3	U6B	-X6	8	A
										K21	-LA	28	A	○		28	STH3	K21	-S1LB	83	
											-LC	28									

SCREEN BUS	↓ FIXED LINK	┌ INSERTABLE JUMPER	⊗ INSULATING WASHER
N-BUS	└ SHORT CIRCUIT LINK	— SECTION INSULATING WASHER	⊗ COVER
PE-BUS			
USED CORES TOTAL			
CONTINUED ON SHEET			

Date	09.05.2023	CLIENT: Transmission Corporation of Andhra Pradesh Limited	SIEMENS LTD.	Descp:245KV,50KA,4000A	SO NO:	Qty:	=ZZA
Prep.	MSR	CONTRACTOR: As applicable	Aurangabad	Type:3AP1FI			++
Ckd.	SB	PROJECT: As applicable		Dwg. Name: Terminal Plan			
Issue	Remarks	Date	Name	ORIGINAL/REPLACEMENT FOR/REPLACED BY:		Drg No: (3)G71AHS-NA403-T1503	Sh. 3
							18 Sh.



1	2	3	4	5	6	7	8
1							
2							
3							
4							
5							
6							
7							
8							
9							
10							

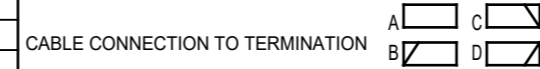
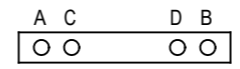

										TERMINATION A/C				TERMINAL STRIP			TYPE	TERMINATION B/D			
										DESTINATION/ITEM DESIGNATION				-LC				DESTINATION/ITEM DESIGNATION			
1	2	3	4	5	6	7	8	9	10					LINK	NO.						
										K15A	-LB	1	A	○		1	STH3	K15A	-K75LC	21	
											-LA	3									
										K114	-Y1LC	A2		○		2	STH3	K114	-LB	2	B
										K15A	-LB	3	A	○		3	STH3	K15A	-S1LC	63	
											-X1	12							-K75LC	13	
										K125	-S1LC	64		○		4	STH3	K123C	-K75LC	A1	
																		K125	-K75LC	14	
										K11	-LB	5	A	○		5	STH3	K11	-S16ALC	1	
											-K15	A1									
										K131C	-S16ALC	4		○		6	STH3	K125C	-K9LC	A1	
										K133C	-S16ALC	2		○		7	STH3	K127C	-K9ALC	A1	
										K71	-LB	8	A	○		8	STH3	K71	-S1LC	19	
											-LA	10									
										K73C	-S1LC	10		○		9	STH3	K73C	-P1LC	1	
										K75B	-LB	12	B	○		10	STH3	K75B	-S1LC	183	
										K77B	-LB	13	B	○		11	STH3	K77B	-S1LC	181	
										K75C	-S1LC	184		○		12	STH3	K75C	-H1	X1	
										K77C	-S1LC	182		○		13	STH3	K77C	-H0	X1	
										K27C	-X2	19	A	○		14	STH3	K27C	-S1LC	191	
										K23C	-K61	34		○		15	STH3	K23C	-S1LC	203	
											-K13	61									
										K204	-Y3LC	A2		○		16	STH3	K204	-LB	16	B
										K223	-LB	18	B	○		17	STH3	K223	-B4LC	21	
										K225	-B4LC	22		○		18	STH3	K225	-X2	24	A
										K57C	-X3	19	A	○		19	STH3	K57C	-S1LC	221	
										K53C	-K12	61		○		20	STH3	K53C	-S1LC	233	
											-K61A	34									
										K304	-Y4LC	A2		○		21	STH3	K304	-LB	21	B
										K323	-LB	23	B	○		22	STH3	K323	-B4LC	31	
										K325	-B4LC	32		○		23	STH3	K325	-X3	24	A
										U3	-X6	3	B	○		24	STH3	U3	-B4LC	13	
										U4	-B4LC	12		○		25	STH3	U4	-X6	4	A
										U5C	-X6	9	A	○		26	STH3	U5C	-S16BLC	2	
										U6C	-S16BLC	1		○		27	STH3	U6C	-X6	10	A
										K21	-LB	28	A	○		28	STH3	K21	-S1LC	83	
										K229	-S1LC	84		○		29	STH3				
										K229	-LB	30	A	○		30	STH3	K229	-S1LC	91	
										K231	-S1LC	92		○		31	STH3	K231	-LB	31	B
										K51	-LB	32	A	○		32	STH3	K51	-S1LC	193	

SCREEN BUS	FIXED LINK	INSERTABLE JUMPER	INSULATING WASHER
N-BUS	SHORT CIRCUIT LINK	SECTION INSULATING WASHER	COVER
PE-BUS			
USED CORES TOTAL			
CONTINUED ON SHEET			

Date	09.05.2023	CLIENT: Transmission Corporation of Andhra Pradesh Limited	SIEMENS LTD.	Descp:245KV,50KA,4000A	SO NO:	Qty:	=ZZA
Prep.	MSR	CONTRACTOR: As applicable	Aurangabad	Type:3AP1FI			++
Ckd.	SB	PROJECT: As applicable		Dwg. Name:Terminal Plan			
Issue	Remarks	Date	Name	ORIGINAL/REPLACEMENT FOR/REPLACED BY:		Drg No: (3)G71AHS-NA403-T1503	Sh. 5
							18 Sh.

A

B

C

D

E

F

A

B

C

D

E

F

THE REPRODUCTION, TRANSMISSION OR USE OF THIS DOCUMENT OR ITS CONTENTS IS NOT PERMITTED UNLESS THE REPRODUCER IS A MEMBER OF THE INSTITUTION OF ELECTRICAL ENGINEERS, INDIA. ALL RIGHTS, INCLUDING RIGHTS CREATED BY WITHOUT EXPRESS WRITTEN AUTHORITY, PATENT GRANT OR REGISTRATION OF A UTILITY MODEL OR DESIGN, ARE RESERVED.

1	2	3	4	5	6	7	8	
CABLE DESTINATION	TYPE, CORE NO., CROSS SECTION	DEST./ITEM DES.	LEVEL	A C D B O O O O		TERMINAL	LINE-UP TERMINAL TYPE	TYPE OF WIRING
1							41xSTH3	1) EQUIPMENT WIRING
2								
3								
4								
5								
6								
7								
8								
9								
10								



										TERMINATION A/C DESTINATION/ITEM DESIGNATION	TERMINAL STRIP -LC	TYPE	TERMINATION B/D DESTINATION/ITEM DESIGNATION						
1	2	3	4	5	6	7	8	9	10		LINK	NO.							
										K329	-S1LC	194		33	STH3				
										K329	-LB	34	A	34	STH3	K329	-S1LC	211	
										K331	-S1LC	212		35	STH3	K331	-LB	35	B
										H55C	-X5	8	B	36	STH3	H15C	-M LC	1	
										H16C	-M LC	2		37	STH3	H74C	-X5	11	A
										H19	-LB	38	A	38	STH3	H19	-R1	1	
											-B1	2				H19	-R1LC	1	
										H13	-R1LC	2		39	STH3	H13	-LB	39	B
										H13	-LB	40	A	40	STH3	H13	-F11LC	1	
											-X5	15							
										H13	-E2LC	2		41	STH3	H13	-E2	2	
																H13	-LB	41	B
										K119C	-K75LC	32		42		K119C	-S1LC	42	
											-LB	DC5	A				-PTLC	1	
											-PTLC	2					-X1	106	A

										SCREEN BUS									
										N-BUS									
										PE-BUS									
										USED CORES TOTAL									
										CONTINUED ON SHEET									

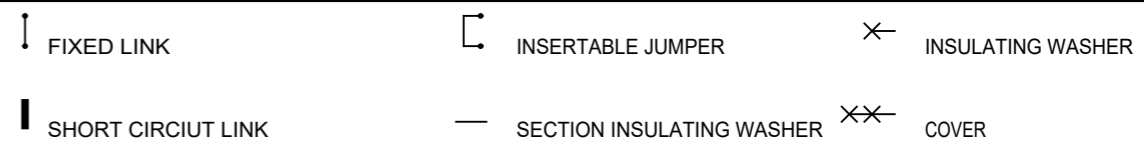

Date	09.05.2023	CLIENT: Transmission Corporation of Andhra Pradesh Limited	SIEMENS LTD.	Descp:245KV,50KA,4000A	SO NO:	Qty:	=ZZA
Prep.	MSR	CONTRACTOR: As applicable	Aurangabad	Type:3AP1FI			++
Ckd.	SB	PROJECT: As applicable		Dwg. Name: Terminal Plan			Sh. 6
Issue	Remarks	Date	Name	ORIGINAL/REPLACEMENT FOR/REPLACED BY:		Drg No: (3)G71AHS-NA403-T1503	18 Sh.



1	CABLE DESTINATION	2	TYPE, CORE NO., CROSS SECTION	3	DEST./ITEM DES.	LEVEL	4		5	6	7	8
							A C	D B				
1							<input type="radio"/>	<input type="radio"/>				
2							<input type="radio"/>	<input type="radio"/>				
3							<input type="radio"/>	<input type="radio"/>				
4							<input type="radio"/>	<input type="radio"/>				
5							<input type="radio"/>	<input type="radio"/>				
6							<input type="radio"/>	<input type="radio"/>				
7							<input type="radio"/>	<input type="radio"/>				
8							<input type="radio"/>	<input type="radio"/>				
9							<input type="radio"/>	<input type="radio"/>				
10							<input type="radio"/>	<input type="radio"/>				

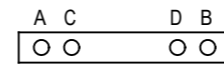

TERMINAL	LINE-UP TERMINAL TYPE	TYPE OF WIRING
	42xSTH3	1) EQUIPMENT WIRING

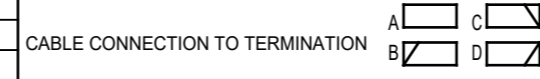

										TERMINATION A/C			TERMINAL STRIP			TYPE	TERMINATION B/D				
										DESTINATION/ITEM DESIGNATION			-X1LA				DESTINATION/ITEM DESIGNATION				
1	2	3	4	5	6	7	8	9	10		LINK	NO.									
										U101A	-S1LA	29				1	STH3				
										U102A	-S1LA	20				2	STH3				
										U103A	-S1LA	103				3	STH3				
										U104A	-S1LA	104				4	STH3				
										U105A	-S1LA	111				5	STH3				
										U106A	-S1LA	112				6	STH3				
										U107A	-S1LA	113				7	STH3				
										U108A	-S1LA	114				8	STH3	U108A	-X1LB	7	B
										U109A	-S1LA	121				9	STH3				
										U110A	-S1LA	122				10	STH3	U110A	-X1LB	9	B
										U111A	-S1LA	123				11	STH3				
										U112A	-S1LA	124				12	STH3	U112A	-X1LB	11	B
										U113A	-S1LA	131				13	STH3				
										U114A	-S1LA	132				14	STH3	U114A	-X1LB	13	B
										U115A	-S1LA	133				15	STH3	U115A	-X1LB	15	B
										U116A	-S1LA	134				16	STH3				
										U117A	-S1LA	141				17	STH3	U117A	-X1LB	17	B
										U118A	-S1LA	142				18	STH3				
										U119A	-S1LA	143				19	STH3	U119A	-X1LB	19	B
										U120A	-S1LA	144				20	STH3				
										U121A	-S1LA	151				21	STH3	U121A	-X1LB	21	B
										U122A	-S1LA	152				22	STH3				
										U123A	-S1LA	153				23	STH3	U123A	-X1LB	23	B
										U124A	-S1LA	154				24	STH3				
										U125A	-S1LA	161				25	STH3	U125A	-X1LB	25	B
										U126A	-S1LA	162				26	STH3				
										U127A	-S1LA	93				27	STH3				
										U128A	-S1LA	94				28	STH3	U128A	-X1LB	27	B
										U129A	-S1LA	71				29	STH3				
										U130A	-S1LA	72				30	STH3	U130A	-X1LB	29	B
										U131A	-S1LA	163				31	STH3				
										U132A	-S1LA	164				32	STH3	U132A	-X1LB	31	B
										U133A	-S1LA	81				33	STH3				
										U134A	-S1LA	82				34	STH3	U134A	-X1LB	33	B
										U135A	-S1LA	173				35	STH3				
										U136A	-S1LA	174				36	STH3	U136A	-X1LB	35	B
										U137A	-S1LA	101				37	STH3				
										U138A	-S1LA	102				38	STH3	U138A	-X1LB	37	B
										U139A	-S1LA	253				39	STH3				
										U140A	-S1LA	254				40	STH3	U140A	-X1LB	39	B

SCREEN BUS										↓ FIXED LINK			┌ INSERTABLE JUMPER			✕ INSULATING WASHER			
N-BUS										SHORT CIRCUIT LINK			— SECTION INSULATING WASHER			✕✕ COVER			
PE-BUS																			
USED CORES TOTAL																			
CONTINUED ON SHEET																			

Date		09.05.2023		CLIENT: Transmission Corporation of Andhra Pradesh Limited			SIEMENS LTD.		Descp:245KV,50KA,4000A		SO NO:		Qty:		=ZZA	
Prep.		MSR		CONTRACTOR: As applicable			Aurangabad		Type:3AP1FI						++	
Ckd.		SB		PROJECT: As applicable					Dwg. Name: Terminal Plan						Sh. 8	
Issue				ORIGINAL/REPLACEMENT FOR/REPLACED BY:									Drg No: (3)G71AHS-NA403-T1503		18 Sh.	

A

B

C

D

E

F

A

B

C

D

E

F

THE REPRODUCTION, TRANSMISSION OR USE OF THIS DOCUMENT OR ITS CONTENTS IS NOT PERMITTED OFFENDERS WILL BE LIABLE FOR DAMAGES. ALL RIGHTS, INCLUDING RIGHTS CREATED BY WITHOUT EXPRESS WRITTEN AUTHORITY, PATENT GRANT OR REGISTRATION OF A UTILITY MODEL OR DESIGN, ARE RESERVED.

1	2	3	4	5	6	7	8	
CABLE DESTINATION	TYPE, CORE NO., CROSS SECTION	DEST./ITEM DES.	LEVEL	A C D B O O O O		TERMINAL	LINE-UP TERMINAL TYPE	TYPE OF WIRING
1							42xSTH3	1) EQUIPMENTWIRING
2								
3								
4								
5								
6								
7								
8								
9								
10								

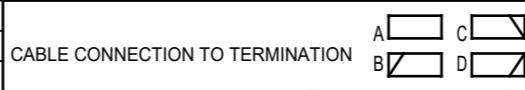

										TERMINATION A/C DESTINATION/ITEM DESIGNATION		TERMINAL STRIP -X1LA	TYPE	TERMINATION B/D DESTINATION/ITEM DESIGNATION	
1	2	3	4	5	6	7	8	9	10			LINK	NO.		
										U141A	-S1LA	171		41	STH3
										U142A	-S1LA	172		42	STH3
															U142A
															-X1LB
															41
															B

SCREEN BUS	↓ FIXED LINK	┌ INSERTABLE JUMPER	⊗ INSULATING WASHER
N-BUS	┆ SHORT CIRCUIT LINK	— SECTION INSULATING WASHER	⊗⊗ COVER
PE-BUS			
USED CORES TOTAL			
CONTINUED ON SHEET			

Date	09.05.2023	CLIENT: Transmission Corporation of Andhra Pradesh Limited	SIEMENS LTD.	Descp:245KV,50KA,4000A	SO NO:	Qty:	=ZZA
Prep.	MSR	CONTRACTOR: As applicable	Aurangabad	Type:3AP1FI			++
Ckd.	SB	PROJECT: As Applicable		Dwg. Name:Terminal Plan			
Issue	Remarks	Date	Name	ORIGINAL/REPLACEMENT FOR/REPLACED BY:		Drg No: (3)G71AHS-NA403-T1503	Sh. 9
							18 Sh.

A

B

C

D

E

F

A

B

C

D

E

F

THE REPRODUCTION, TRANSMISSION OR USE OF THIS DOCUMENT OR ITS CONTENTS IS NOT PERMITTED UNLESS THE REPRODUCER IS AWARE OF THE DAMAGE TO THE ORIGINAL DOCUMENT. ALL RIGHTS, INCLUDING RIGHTS CREATED BY WITHOUT EXPRESS WRITTEN AUTHORITY, PATENT OR REGISTRATION OF A UTILITY MODEL OR DESIGN, ARE RESERVED.

1	2	3	4	5	6	7	8	
CABLE DESTINATION	TYPE, CORE NO., CROSS SECTION	DEST./ITEM DES.	LEVEL	A C D B O O O O		TERMINAL	LINE-UP TERMINAL TYPE	TYPE OF WIRING
1							42xSTH3	1) EQUIPMENTWIRING
2								
3								
4								
5								
6								
7								
8								
9								
10								

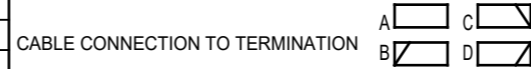

										TERMINATION A/C DESTINATION/ITEM DESIGNATION		TERMINAL STRIP -X1LB	TYPE	TERMINATION B/D DESTINATION/ITEM DESIGNATION					
1	2	3	4	5	6	7	8	9	10			LINK	NO.						
										U101B	-S1LB	29		1	STH3				
										U102B	-S1LB	20		2	STH3				
										U103B	-S1LB	103		3	STH3				
										U104B	-S1LB	104		4	STH3				
										U105B	-S1LB	111		5	STH3				
										U106B	-S1LB	112		6	STH3				
										U108A	-S1LB	113		7	STH3	U108A	-X1LA	8	B
										U108B	-S1LB	114		8	STH3	U108B	-X1LC	7	B
										U110A	-S1LB	121		9	STH3	U110A	-X1LA	10	B
										U110B	-S1LB	122		10	STH3	U110B	-X1LC	9	B
										U112A	-S1LB	123		11	STH3	U112A	-X1LA	12	B
										U112B	-S1LB	124		12	STH3	U112B	-X1LC	11	B
										U114A	-S1LB	131		13	STH3	U114A	-X1LA	14	B
										U114B	-S1LB	132		14	STH3	U114B	-X1LC	13	B
										U115A	-S1LB	133		15	STH3	U115A	-X1LA	15	B
																U115A	-X1LC	15	B
										U116B	-S1LB	134		16	STH3				
										U117A	-S1LB	141		17	STH3	U117A	-X1LC	17	B
																U117A	-X1LA	17	B
										U118B	-S1LB	142		18	STH3				
										U119A	-S1LB	143		19	STH3	U119A	-X1LC	19	B
																U119A	-X1LA	19	B
										U120B	-S1LB	144		20	STH3				
										U121A	-S1LB	151		21	STH3	U121A	-X1LA	21	B
																U121A	-X1LC	21	B
										U122B	-S1LB	152		22	STH3				
										U123A	-S1LB	153		23	STH3	U123A	-X1LA	23	B
																U123A	-X1LC	23	B
										U124B	-S1LB	154		24	STH3				
										U125A	-S1LB	161		25	STH3	U125A	-X1LA	25	B
																U125A	-X1LC	25	B
										U126B	-S1LB	162		26	STH3				
										U128A	-S1LB	93		27	STH3	U128A	-X1LA	28	B
										U128B	-S1LB	94		28	STH3	U128B	-X1LC	27	B
										U130A	-S1LB	71		29	STH3	U130A	-X1LA	30	B
										U130B	-S1LB	72		30	STH3	U130B	-X1LC	29	B
										U132A	-S1LB	163		31	STH3	U132A	-X1LA	32	B
										U132B	-S1LB	164		32	STH3	U132B	-X1LC	31	B
										U134A	-S1LB	81		33	STH3	U134A	-X1LA	34	B

SCREEN BUS	↓ FIXED LINK	┌ INSERTABLE JUMPER	⊗ INSULATING WASHER
N-BUS	└ SHORT CIRCUIT LINK	— SECTION INSULATING WASHER	⊗⊗ COVER
PE-BUS			
USED CORES TOTAL			
CONTINUED ON SHEET			

Date	09.05.2023	CLIENT: Transmission Corporation of Andhra Pradesh Limited	SIEMENS LTD.	Descp:245KV,50KA,4000A	SO NO:	Qty:	=ZZA
Prep.	MSR	CONTRACTOR: As applicable	Aurangabad	Type:3AP1FI			++
Ckd.	SB	PROJECT: As applicable		Dwg. Name: Terminal Plan			
Issue	Remarks	Date	Name	ORIGINAL/REPLACEMENT FOR/REPLACED BY:		Drg No: (3)G71AHS-NA403-T1503	Sh. 10
							18 Sh.



1	2	3	4	5	6	7	8	
CABLE DESTINATION	TYPE, CORE NO., CROSS SECTION	DEST./ITEM DES.	LEVEL	A C D B O O O O		TERMINAL	LINE-UP TERMINAL TYPE	TYPE OF WIRING
1							42xSTH3	1) EQUIPMENT WIRING
2								
3								
4								
5								
6								
7								
8								
9								
10								

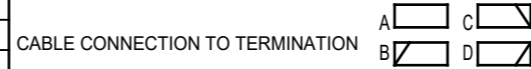

										TERMINATION A/C DESTINATION/ITEM DESIGNATION		TERMINAL STRIP -X1LC	TYPE	TERMINATION B/D DESTINATION/ITEM DESIGNATION						
1	2	3	4	5	6	7	8	9	10		LINK	NO.								
										U101C	-S1LC	29	O		1	STH3				
										U102C	-S1LC	20	O		2	STH3				
										U103C	-S1LC	103	O		3	STH3				
										U104C	-S1LC	104	O		4	STH3				
										U105C	-S1LC	111	O		5	STH3				
										U106C	-S1LC	112	O		6	STH3				
										U108B	-S1LC	113	O		7	STH3	U108B	-X1LB	8	B
										U108C	-S1LC	114	O		8	STH3				
										U110B	-S1LC	121	O		9	STH3	U110B	-X1LB	10	B
										U110C	-S1LC	122	O		10	STH3				
										U112B	-S1LC	123	O		11	STH3	U112B	-X1LB	12	B
										U112C	-S1LC	124	O		12	STH3				
										U114B	-S1LC	131	O		13	STH3	U114B	-X1LB	14	B
										U114C	-S1LC	132	O		14	STH3				
										U115A	-S1LC	133	O		15	STH3	U115A	-X1LB	15	B
										U116C	-S1LC	134	O		16	STH3				
										U117A	-S1LC	141	O		17	STH3	U117A	-X1LB	17	B
										U118C	-S1LC	142	O		18	STH3				
										U119A	-S1LC	143	O		19	STH3	U119A	-X1LB	19	B
										U120C	-S1LC	144	O		20	STH3				
										U121A	-S1LC	151	O		21	STH3	U121A	-X1LB	21	B
										U122C	-S1LC	152	O		22	STH3				
										U123A	-S1LC	153	O		23	STH3	U123A	-X1LB	23	B
										U124C	-S1LC	154	O		24	STH3				
										U125A	-S1LC	161	O		25	STH3	U125A	-X1LB	25	B
										U126C	-S1LC	162	O		26	STH3				
										U128B	-S1LC	93	O		27	STH3	U128B	-X1LB	28	B
										U128C	-S1LC	94	O		28	STH3				
										U130B	-S1LC	71	O		29	STH3	U130B	-X1LB	30	B
										U130C	-S1LC	72	O		30	STH3				
										U132B	-S1LC	163	O		31	STH3	U132B	-X1LB	32	B
										U132C	-S1LC	164	O		32	STH3				
										U134B	-S1LC	81	O		33	STH3	U134B	-X1LB	34	B
										U134C	-S1LC	82	O		34	STH3				
										U136B	-S1LC	173	O		35	STH3	U136B	-X1LB	36	B
										U136C	-S1LC	174	O		36	STH3				
										U138B	-S1LC	101	O		37	STH3	U138B	-X1LB	38	B
										U138C	-S1LC	102	O		38	STH3				
										U140B	-S1LC	253	O		39	STH3	U140B	-X1LB	40	B
										U140C	-S1LC	254	O		40	STH3				

SCREEN BUS	↓ FIXED LINK	┌ INSERTABLE JUMPER	✕ INSULATING WASHER
N-BUS	↓ SHORT CIRCUIT LINK	— SECTION INSULATING WASHER	✕✕ COVER
PE-BUS			
USED CORES TOTAL			
CONTINUED ON SHEET			

Date	09.05.2023	CLIENT: Transmission Corporation of Andhra Pradesh Limited	SIEMENS LTD.	Descp:245KV,50KA,4000A	SO NO:	Qty:	=ZZA
Prep.	MSR	CONTRACTOR: As applicable	Aurangabad	Type:3AP1FI			++
Ckd.	SB	PROJECT: As applicable		Dwg. Name:Terminal Plan			
Issue	Remarks	Date	Name	ORIGINAL/REPLACEMENT FOR/REPLACED BY:		Drg No: (3)G71AHS-NA403-T1503	Sh. 12
							18 Sh.



A

B

C

D

E

F

A

B

C

D

E

F

THE REPRODUCTION, TRANSMISSION OR USE OF THIS DOCUMENT OR ITS CONTENTS IS NOT PERMITTED UNLESS THE REPRODUCER IS AWARE OF THE DAMAGE TO THE ORIGINAL DOCUMENT. ALL RIGHTS, INCLUDING RIGHTS CREATED BY WITHOUT EXPRESS WRITTEN AUTHORITY, PATENT GRANT OR REGISTRATION OF A UTILITY MODEL OR DESIGN, ARE RESERVED.

1	2	3	4	5	6	7	8	
CABLE DESTINATION	TYPE, CORE NO., CROSS SECTION	DEST./ITEM DES.	LEVEL	A C D B O O O O		TERMINAL	LINE-UP TERMINAL TYPE	TYPE OF WIRING
1							2xCSTSN5U	1)
2							24xSTH3	EQUIPMENTWIRING
3								
4								
5								
6								
7								
8								
9								
10								

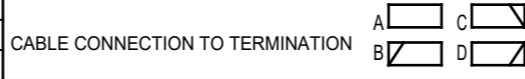

										TERMINATION A/C DESTINATION/ITEM DESIGNATION		TERMINAL STRIP -X2	TYPE	TERMINATION B/D DESTINATION/ITEM DESIGNATION				
1	2	3	4	5	6	7	8	9	10			LINK	NO.					
										J21	-F19	1	O	1	CSTSN5U			
										J22	-F19	3	O	2	CSTSN5U			
										K21	-F19	2	O	3	STH3			
										K22	-F19	4	O	4	STH3			
													O	5	STH3	K21	-F19	2
													O	6	STH3	K21	-S21	13
										K21	-K61	13	O	7	STH3	K21	-X2	26 B
													O	8	STH3	K21	-K77	13
													O	9	STH3	K21	-K61	33
													O	10	STH3	K21	-K77	23
													O	11	STH3	K21	-S22	21
													O	12	STH3	K21	-K77	33
													O	13	STH3	K25R	-S13	B2
										K23A	-K77	14	O	14	STH3			
										K23B	-K77	24	O	15	STH3			
													O	16	STH3	K23C	-K77	34
										K27A	-LA	14 A	O	17	STH3			
										K23A	-K61	14	O	18	STH3			
										K27B	-LB	14 B	O	19	STH3			
										K23B	-K61	24	O	20	STH3			
										K27C	-LC	14 A	O	21	STH3			
										K23C	-K61	34	O	22	STH3			
										K22	-K77	A2	O	23	STH3	K22	-K12	A2
										K22	-K10	14	O	24	STH3	K22	-X2	23 B
													O	25	STH3			
													O	26	STH3			
										K22	-K16	A2	O	27	STH3	K22	-X2	22 B
										K225	-LC	18 B	O	28	STH3	K225	-K10	A1
										K219	-LK1	2	O	29	STH3	K219	-CTD1	5
													O	30	STH3			
										K21	-LA	28 A	O	31	STH3	K21	-X2	7 B
													O	32	STH3			
													O	33	STH3			
													O	34	STH3			
													O	35	STH3			
													O	36	STH3			
													O	37	STH3			
													O	38	STH3			
													O	39	STH3			
													O	40	STH3			

SCREEN BUS	↓ FIXED LINK	┌ INSERTABLE JUMPER	⊗ INSULATING WASHER
N-BUS	┆ SHORT CIRCUIT LINK	— SECTION INSULATING WASHER	⊗⊗ COVER
PE-BUS			
USED CORES TOTAL			
CONTINUED ON SHEET			

Date	09.05.2023	CLIENT: Transmission Corporation of Andhra Pradesh Limited	SIEMENS LTD.	Descp:245KV,50KA,4000A	SO NO:	Qty:	=ZZA
Prep.	MSR	CONTRACTOR: As applicable	Aurangabad	Type:3AP1FI			++
Ckd.	SB	PROJECT: As applicable		Dwg. Name:Terminal Plan			
Issue	Remarks	Date	Name	ORIGINAL/REPLACEMENT FOR/REPLACED BY:		Drg No: (3)G71AHS-NA403-T1503	Sh. 14
							18 Sh.



A

B

C

D

E

F

A

B

C

D

E

F

THE REPRODUCTION, TRANSMISSION OR USE OF THIS DOCUMENT OR ITS CONTENTS IS NOT PERMITTED OFFENDERS WILL BE LIABLE FOR DAMAGES. ALL RIGHTS, INCLUDING RIGHTS CREATED BY WITHOUT EXPRESS WRITTEN AUTHORITY, PATENT GRANT OR REGISTRATION OF A UTILITY MODEL OR DESIGN, ARE RESERVED.

1	2	3	4	5	6	7	8
CABLE DESTINATION	TYPE, CORE NO., CROSS SECTION	DEST./ITEM DES.	LEVEL		TERMINAL	LINE-UP TERMINAL TYPE	TYPE OF WIRING
1						2xCSTSN5U	1)
2						13xSTH3	EQUIPMENTWIRING
3							
4							
5							
6							
7							
8							
9							
10							

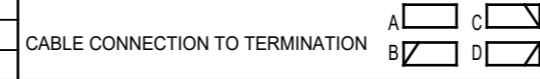
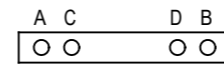

										TERMINATION A/C DESTINATION/ITEM DESIGNATION				TERMINAL STRIP -X4			TYPE	TERMINATION B/D DESTINATION/ITEM DESIGNATION			
1	2	3	4	5	6	7	8	9	10					LINK NO.							
										J71	-F23	1				1	CSTSN5U				
										J72	-F23	3				2	CSTSN5U				
										K71	-F23	2				3	STH3	K71	-LA	8	A
										K72	-P1LA	2				4	STH3	K72	-F23	4	
										K72	-P1LC	2				5	STH3	K72	-P1LB	2	
																6	STH3		-H1	X2	
																7	STH3				
																8	STH3				
																9	STH3				
																10	STH3				
																11	STH3				
																12	STH3				
																13	STH3				
																14	STH3				
																15	STH3				

										SCREEN BUS		↓ FIXED LINK	┌ INSERTABLE JUMPER	⊗ INSULATING WASHER
										N-BUS		└ SHORT CIRCUIT LINK	— SECTION INSULATING WASHER	⊗⊗ COVER
										PE-BUS				
										USED CORES TOTAL				
										CONTINUED ON SHEET				

Date	09.05.2023	CLIENT: Transmission Corporation of Andhra Pradesh Limited	SIEMENS LTD.	Descp:245KV,50KA,4000A	SO NO:	Qty:	=ZZA
Prep.	MSR	CONTRACTOR: As applicable	Aurangabad	Type:3AP1FI			++
Ckd.	SB	PROJECT: As applicable		Dwg. Name: Terminal Plan			
Issue	Remarks	Date	Name	ORIGINAL/REPLACEMENT FOR/REPLACED BY:		Drg No: (3)G71AHS-NA403-T1503	Sh. 16
							18 Sh.

A

A

B

B

C

C

D

D

E

E

F

F

THE REPRODUCTION, TRANSMISSION OR USE OF THIS DOCUMENT OR ITS CONTENTS IS NOT PERMITTED UNLESS THE REPRODUCER HAS OBTAINED THE WRITTEN PERMISSION OF THE AUTHOR OR HIS SUCCESSORS IN TITLE. ALL RIGHTS, INCLUDING RIGHTS OF PATENT, TRADE MARK OR DESIGN, ARE RESERVED.

1	2	3	4	5	6	7	8
CABLE DESTINATION	TYPE, CORE NO., CROSS SECTION	DEST./ITEM DES.	LEVEL		TERMINAL	LINE-UP TERMINAL TYPE	TYPE OF WIRING
1						5xCSTSN5U	1)
2						10xSTH3	EQUIPMENTWIRING
3							
4							
5							
6							
7							
8							
9							
10							

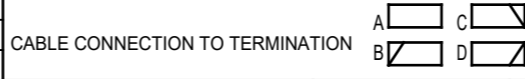
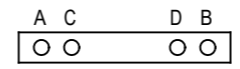



										TERMINATION A/C DESTINATION/ITEM DESIGNATION		TERMINAL STRIP -X5	TYPE	TERMINATION B/D DESTINATION/ITEM DESIGNATION
1	2	3	4	5	6	7	8	9	10		LINK	NO.		
												1	CSTSN5U	H11A -F16 1
										H3 -X5 5 B		2	CSTSN5U	H31B -F16 3
												3	CSTSN5U	H51C -F16 5
												4	CSTSN5U	H71 -F16 N
										H51C -F20 1		5	CSTSN5U	H3 -X5 3 A
										H15A -K9LA 14		6	STH3	H15A -LA 36 A
										H15B -K9LB 14		7	STH3	H35B -LB 36 A
										H15C -K9LC 14		8	STH3	H55C -LC 36 A
										H74A -LA 37 B		9	STH3	H16A -K9LA 43
										H74B -LB 37 B		10	STH3	H16B -K9LB 43
										H74C -LC 37 B		11	STH3	H16C -K9LC 43
										H72 -F16 N1		12	STH3	
										-K9LA 44		13	STH3	H12 -K9LC 44
												14	STH3	H72 -F20 3
										H13 -LB 39 B		15	STH3	H13 -R1 2
										-X20 N				H74 -F20 4
										H51 -F11 1				H13 -LC 40 A

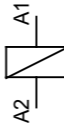
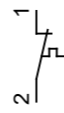

SCREEN BUS	FIXED LINK	INSERTABLE JUMPER	INSULATING WASHER
N-BUS	SHORT CIRCUIT LINK	SECTION INSULATING WASHER	COVER
PE-BUS			
USED CORES TOTAL			
CONTINUED ON SHEET			

Date	09.05.2023	CLIENT: Transmission Corporation of Andhra Pradesh Limited	SIEMENS LTD.	Descp:245KV,50KA,4000A	SO NO:	Qty:	=ZZA
Prep.	MSR	CONTRACTOR: As applicable	Aurangabad	Type:3AP1FI			++
Ckd.	SB	PROJECT: As applicable		Dwg. Name:Terminal Plan			
Issue	Remarks	Date	Name	ORIGINAL/REPLACEMENT FOR/REPLACED BY:		Drg No: (3)G71AHS-NA403-T1503	Sh. 17
							18 Sh.



1	2	3	4	5	6	7	8
DESIGNATION / TECHNICAL DATA	QTY.	ITEM DESIGNATION	FUNCTIONS	TOTAL ITEM REPRESENTATION AND OTHER TECHNICAL DATA			
COIL 220VDC 330W  INSPROSS/SUBHNEEL/Eq	9.00			 NOTE: 1. Drawings Approval subject to valid type test reports, to be checked during acceptance tests. 2.For EPC contractors only.			
		=ZZA++-Y1LA	CLOSE COIL FOR POLE A	=WD&EFS/2.3			
		=ZZA++-Y1LB	CLOSE COIL FOR POLE B	=WD&EFS/2.4			
		=ZZA++-Y1LC	CLOSE COIL FOR POLE C	=WD&EFS/2.5			
		=ZZA++-Y3LA	TRIP COIL - 1 FOR POLE A	=WD&EFS/4.3			
		=ZZA++-Y3LB	TRIP COIL - 1 FOR POLE B	=WD&EFS/4.5			
		=ZZA++-Y3LC	TRIP COIL - 1 FOR POLE C	=WD&EFS/4.6			
		=ZZA++-Y4LA	TRIP COIL - 2 FOR POLE A	=WD&EFS/5.3			
		=ZZA++-Y4LB	TRIP COIL - 2 FOR POLE B	=WD&EFS/5.5			
		=ZZA++-Y4LC	TRIP COIL - 2 FOR POLE C	=WD&EFS/5.6			
THERMOSTAT 0-60 deg C  Xexagon / Girish Ego/ APT/Eq	1.00			 Drawing approval subject to valid vendor registration			
		=ZZA++-B1	THERMOSTATE	=WD&EFS/8.6			
10 A  SIEMENS/Eq	4.00						
		=ZZA++-LK1	LINK	=WD&EFS/4.7			
		=ZZA++-LK2	LINK	=WD&EFS/4.7			
		=ZZA++-LK3	LINK	=WD&EFS/5.7			
		=ZZA++-LK4	LINK	=WD&EFS/5.7			
1. Minimum 300mm plinth shall be maintained for CT/PT/CVT/Isolators/IV/LA/Breakers in the substation during foundation works to ensure safe live to ground clearance per IE rules. 2. Since the supply of terminal connectors is not in the scope of manufacturer as mentioned in the drawings. The EPC contractor shall be instructed to supply the same line with CT/PT/CVT/Isolator/IVT/LA/Breaker's requirement and compatibility.				<b>CHIEF ENGINEER/PROJECTS</b> <b>APTRANSCO/VISVIJAYAWADA</b>			
Date		09.05.2023		CLIENT: Transmission Corporation of Andhra Pradesh Limited		SIEMENS LTD.	
Prep.		MSR		CONTRACTOR:As applicable		Descp:245KV,50KA,4000A	
Ckd.		SB		PROJECT: As Applicable		Type:3AP1FI	
Issue		Remarks		Date		Name	
ORIGINAL/REPLACEMENT FOR/REPLACED BY:				SO NO:		Qty:	
				Dwg. Name:Equipment List		Sh. 1	
				Drg No: (3)G71AHS-NA403-E1503		10 Sh.	

THE REPRODUCTION, TRANSMISSION OR USE OF THIS DOCUMENT OR ITS CONTENTS IS NOT PERMITTED UNLESS THE REPRODUCER IS A UTILITY MODEL OR DESIGN, ARE RESERVED.

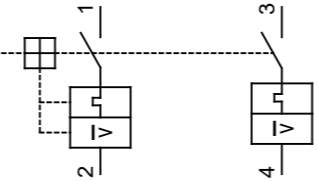
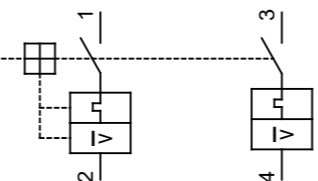
1	2	3	4	5	6	7	8		
DESIGNATION / TECHNICAL DATA	QTY.	ITEM DESIGNATION	FUNCTIONS	TOTAL ITEM REPRESENTATION AND OTHER TECHNICAL DATA					
RESISTOR 100WATT 230VAC  GIRISH EGO/VELICO/Eq	4.00			 NOTE: 1. Drawings Approval subject to valid type test reports, to be checked during acceptance tests. 2.For EPC contractors only.					
		=ZZA+++R1	HEATER					=WD&EFS/8.6	
		=ZZA+++R1LA	SPACE HEATER FOR POLE A					=WD&EFS/8.5	
		=ZZA+++R1LB	SPACE HEATER FOR POLE B					=WD&EFS/8.6	
		=ZZA+++R1LC	SPACE HEATER FOR POLE C					=WD&EFS/8.6	
PRESSURE TRANSDUCER 12719260 SIGNAL RANGE 4-20mA WIKA/Eq	3.00								
		=ZZA+++PTLA	PRESSURE TRANSDUCER					=WD&EFS/8.6	
		=ZZA+++PTLB	PRESSURE TRANSDUCER					=WD&EFS/8.6	
		=ZZA+++PTLC	PRESSURE TRANSDUCER					=WD&EFS/8.6	
MCB 2 POLE 16A 440VDC SIEMENS/C&S/Eq	4.00								
		=ZZA+++F19	MCB FOR DC SUPPLY - 1					=WD&EFS/4.2	=WD&EFS/4.1
		=ZZA+++F21	MCB FOR DC SUPPLY - 2					=WD&EFS/5.2	=WD&EFS/5.1
		=ZZA+++F22	MCB FOR CLOSING CKT					=WD&EFS/2.2	=WD&EFS/2.1
		=ZZA+++F23	MCB FOR INDICATION CKT					=WD&EFS/3.5	=WD&EFS/3.5
MCB 2 POLE 10A 400VAC SIEMENS/C&S/Eq	1.00								
		=ZZA+++F20	MCB FOR UTILITY CIRCUIT					=WD&EFS/8.4	=WD&EFS/8.4
1. Minimum 300mm plinth shall be maintained for CT/PT/CVT/Isolators/IV/LA/Breakers in the substation during foundation works to ensure safe live to ground clearance per IE rules. 2. Since the supply of terminal connectors is not in the scope of manufacturer as mentioned in the drawings. The EPC contractor shall be instructed to supply the same line with CT/PT/CVT/Isolator/IVT/LA/Breaker's requirement and compatibility.									
Date		09.05.2023		CLIENT: Transmission Corporation of Andhra Pradesh Limited		SIEMENS LTD.			
Prep.		MSR		CONTRACTOR: As applicable		Descp:245KV,50KA,4000A			
Ckd.		SB		PROJECT: As Applicable		Type:3AP1FI			
Issue		Remarks		Date		Name			
Date		Name		ORIGINAL/REPLACEMENT FOR/REPLACED BY:		SO NO: Qty:			
Date		Name		ORIGINAL/REPLACEMENT FOR/REPLACED BY:		Drg No: (3)G71AHS-NA403-E1503			
Date		Name		ORIGINAL/REPLACEMENT FOR/REPLACED BY:		Sh. 2			
Date		Name		ORIGINAL/REPLACEMENT FOR/REPLACED BY:		10 Sh.			

THE REPRODUCTION, TRANSMISSION OR USE OF THIS DOCUMENT OR ITS CONTENTS IS NOT PERMITTED UNLESS THE REPRODUCER IS NOTIFIED BY THE COPYRIGHT OWNER. ALL RIGHTS, INCLUDING RIGHTS CREATED BY WITHOUT EXPRESS WRITTEN AUTHORITY, PATENT GRANT OR REGISTRATION OF A UTILITY MODEL OR DESIGN, ARE RESERVED.

**CHIEF ENGINEER/PROJECTS  
APTRANSCO/VISVIJAYAWADA**

**SIEMENS LTD.**  
Aurangabad

Descp:245KV,50KA,4000A  
Type:3AP1FI  
Dwg. Name:Equipment List

SO NO: Qty:  
Drg No: (3)G71AHS-NA403-E1503

Sh. 2  
10 Sh.

1	2	3	4	5	6	7	8
DESIGNATION / TECHNICAL DATA	QTY.	ITEM DESIGNATION	FUNCTIONS	TOTAL ITEM REPRESENTATION AND OTHER TECHNICAL DATA			
INDICATING LAMP 220 VDC AMBER  SIEMENS/TEKNIC/ELAPTRON/Eq	2.00	=ZZA+++H5	CTD 1 HEALTHY INDICATION		NOTE: 1. Drawings Approval subject to valid type test reports, to be checked during acceptance tests. 2.For EPC contractors only.		
		=ZZA+++H6	CTD 2 HEALTHY INDICATION	=WD&EFS/4.7			
		=ZZA+++H6	CTD 2 HEALTHY INDICATION	=WD&EFS/5.7			
INDICATING LAMP 220 VDC BLUE  SIEMENS/TEKNIC/LAPTRON/Eq	1.00	=ZZA+++H2	SPRING CHARGED INDICATION		CHIEF ENGINEER/PROJECTS APTRANSCO/VISVIJAYAWADA		
		=ZZA+++H0	BREAKER OFF INDICATION	=WD&EFS/3.8			
INDICATING LAMP 220 VDC GREEN  SIEMENS/TEKNIC/LAPTRON/Eq	1.00	=ZZA+++H0	BREAKER OFF INDICATION		CHIEF ENGINEER/PROJECTS APTRANSCO/VISVIJAYAWADA		
		=ZZA+++H1	BREAKER ON INDICATION	=WD&EFS/3.7			
INDICATING LAMP 220 VDC RED  SIEMENS/TEKNIC/LAPTRON/Eq	1.00	=ZZA+++H1	BREAKER ON INDICATION		CHIEF ENGINEER/PROJECTS APTRANSCO/VISVIJAYAWADA		
		=ZZA+++P1LA	COUNTER FOR POLE A	=WD&EFS/3.5			
		=ZZA+++P1LB	COUNTER FOR POLE B	=WD&EFS/3.6			
		=ZZA+++P1LC	COUNTER FOR POLE C	=WD&EFS/3.6			
IMPULSE COUNTER 220VDC NON-RESETABLE  GIC/Eq	3.00	=ZZA+++P1LA	COUNTER FOR POLE A		CHIEF ENGINEER/PROJECTS APTRANSCO/VISVIJAYAWADA		
		=ZZA+++P1LB	COUNTER FOR POLE B	=WD&EFS/3.5			
SOCKET 240V 5A  ANCHOR/MDS/Eq	1.00	=ZZA+++X20	SOCKET		1. Minimum 300mm plinth shall be maintained for CT/PT/CVT/Isolators/IV/LA/Breakers in the substation during foundation works to ensure safe live to ground clearance per IE rules. 2. Since the supply of terminal connectors is not in the scope of manufacturer as mentioned in the drawings. The EPC contractor shall be instructed to supply the same line with CT/PT/CVT/Isolator/IVT/LA/Breaker's requirement and compatibility.		
		=ZZA+++X20	SOCKET	=WD&EFS/8.7			

THE REPRODUCTION, TRANSMISSION OR USE OF THIS DOCUMENT OR ITS CONTENTS IS NOT PERMITTED UNLESS THE REPRODUCER IS NOT PERMITTED OFFENDERS WILL BE LIABLE FOR DAMAGES. ALL RIGHTS, INCLUDING RIGHTS CREATED BY WITHOUT EXPRESS WRITTEN AUTHORITY, PATENT GRANT OR REGISTRATION OF A UTILITY MODEL OR DESIGN, ARE RESERVED.

Date	09.05.2023	CLIENT: Transmission Corporation of Andhra Pradesh Limited	SIEMENS LTD.	Descp:245KV,50KA,4000A	SO NO:	Qty:	
Prep.	MSR	CONTRACTOR:As applicable	Aurangabad	Type:3AP1FI			
Ckd.	SB	PROJECT: As Applicable		Dwg. Name:Equipment List			
Issue	Remarks	Date	Name	ORIGINAL/REPLACEMENT FOR/REPLACED BY:		Drg No: (3)G71AHS-NA403-E1503	Sh. 3 10 Sh.



1	2	3	4	5	6	7	8		
DESIGNATION / TECHNICAL DATA	QTY.	ITEM DESIGNATION	FUNCTIONS	TOTAL ITEM REPRESENTATION AND OTHER TECHNICAL DATA					
AUXILIARY CONTACTOR 2NO+2NC & add on 1NO+3NC 220V DC SIEMENS/C&S/Eq	2.00								
		=ZZA++-K12	DC SUPPLY 1 MONITORING	=WD&EFS/4.2	=WD&EFS/5.7	=WD&EFS/5.8	=WD&EFS/7.3	=WD&EFS/5.8	=WD&EFS/4.7
		=ZZA++-K13	DC SUPPLY -2 MONITORING	=WD&EFS/5.2	=WD&EFS/7.4	=WD&EFS/4.7	=WD&EFS/4.8	=WD&EFS/4.8	=WD&EFS/5.7
AUXILIARY CONTACTOR 2NO+2NC 230V AC SIEMENS/C&S/Eq	1.00								
		=ZZA++-K3	UTILITY CIRCUIT MONITORING	=WD&EFS/8.4	=WD&EFS/7.8	=WD&EFS/7.8			
AUXILIARY CONTACTOR 2NO+2NC & ADD ON 2NO+2NC 220V DC SIEMENS/C&S/Eq	3.00								
		=ZZA++-K75LA	ANTI PUMPING DEVICE	=WD&EFS/2.6	=WD&EFS/2.6	=WD&EFS/2.3	=WD&EFS/2.3		
		=ZZA++-K75LB	ANTI PUMPING DEVICE	=WD&EFS/2.6	=WD&EFS/2.7	=WD&EFS/2.4	=WD&EFS/2.4		
		=ZZA++-K75LC	ANTI PUMPING DEVICE	=WD&EFS/2.7	=WD&EFS/2.7	=WD&EFS/2.5	=WD&EFS/2.5		
AUXILIARY CONTACTOR 4NO 220V DC SIEMENS/C&S/Eq	7.00								
		=ZZA++-K9LA	MOTOR CONTROL	=WD&EFS/3.2	=WD&EFS/8.2		=WD&EFS/8.2		
		=ZZA++-K9LB	MOTOR CONTROL	=WD&EFS/3.2	=WD&EFS/8.3		=WD&EFS/8.3		
		=ZZA++-K9LC	MOTOR CONTROL	=WD&EFS/3.3	=WD&EFS/8.3		=WD&EFS/8.3		
		=ZZA++-K14	INDICATION SUPPLY MONITOR	=WD&EFS/3.8			=WD&EFS/7.5		
		=ZZA++-K15	CLOSE,INDICATION,SPRING SUPPLY MONITORING	=WD&EFS/3.4			=WD&EFS/7.5		
		=ZZA++-K77	MANUAL TRIP - 1	=WD&EFS/4.2	=WD&EFS/4.4	=WD&EFS/4.5	=WD&EFS/4.6		
		=ZZA++-K88	MANUAL TRIP - 2	=WD&EFS/5.2	=WD&EFS/5.4	=WD&EFS/5.5	=WD&EFS/5.6		
NOTE: 1. Drawings Approval subject to valid type test reports, to be checked during acceptance tests. 2.For EPC contractors only.			<b>CHIEF ENGINEER/PROJECTS</b> <b>APTRANSCO/VISVIJAYAWADA</b>						
Date		09.05.2023		CLIENT: Transmission Corporation of Andhra Pradesh Limited		SO NO:			
Prep.		MSR		CONTRACTOR: As applicable		Qty:			
Ckd.		SB		PROJECT: As applicable					
Issue				PO.NO.: As applicable					
ORIGINAL/REPLACEMENT FOR/REPLACED BY:				SIEMENS LTD.		Descp:245KV,50KA,4000A			
				Aurangabad		Type:3AP1FI			
						Dwg. Name:Equipment List			
						Sh. 4			
						Drg No: (3)G71AHS-NA403-E1503			
						10 Sh.			

1	2	3	4	5	6	7	8			
DESIGNATION / TECHNICAL DATA	QTY.	ITEM DESIGNATION	FUNCTIONS	TOTAL ITEM REPRESENTATION AND OTHER TECHNICAL DATA						
A AUXILIARY CONTACTOR 4NO & ADD ON 4NC 220V DC SIEMENS/C&S/Eq	3.00									
		=ZZA++-K9ALA	FOR SPRING CHARGED STATUS	=WD&EFS/3.2	=WD&EFS/2.3	=WD&EFS/3.8	=WD&EFS/7.3	=WD&EFS/7.4	=WD&EFS/7.4	=WD&EFS/7.1
		=ZZA++-K9ALB	FOR SPRING CHARGED STATUS	=WD&EFS/3.3	=WD&EFS/2.3	=WD&EFS/3.8	=WD&EFS/7.3	=WD&EFS/7.4	=WD&EFS/7.4	=WD&EFS/7.2
		=ZZA++-K9ALC	FOR SPRING CHARGED STATUS	=WD&EFS/3.3	=WD&EFS/2.3	=WD&EFS/3.8	=WD&EFS/7.3	=WD&EFS/7.4	=WD&EFS/7.4	=WD&EFS/7.2
B AUXILIARY CONTACTOR 4NO & ADD ON 2NO+2NC 220V DC SIEMENS/C&S/Eq	4.00									
		=ZZA++-K10	GENERAL LOCKOUT	=WD&EFS/4.8	=WD&EFS/4.3	=WD&EFS/4.7	=WD&EFS/2.2	=WD&EFS/7.3	=WD&EFS/6.5	=WD&EFS/7.1
		=ZZA++-K10A	GENERAL LOCKOUT	=WD&EFS/5.8	=WD&EFS/5.3	=WD&EFS/5.7	=WD&EFS/2.2	=WD&EFS/7.3	=WD&EFS/6.5	=WD&EFS/7.1
		=ZZA++-K61	ENFORCED TRIPLE POLE OPERATION	=WD&EFS/6.1	=WD&EFS/4.3	=WD&EFS/4.4	=WD&EFS/4.6		=WD&EFS/2.2	
		=ZZA++-K61A	ENFORCED TRIPLE POLE OPERATION	=WD&EFS/6.3	=WD&EFS/5.3	=WD&EFS/5.4	=WD&EFS/5.6		=WD&EFS/2.2	
C ON-DELAY 3RP1525-1BW30 24-240VAC/DC SIEMENS/GIC/Eq	2.00									
		=ZZA++-K16	ON DELAY TIMER	=WD&EFS/6.2	=WD&EFS/6.1	=WD&EFS/7.6				
		=ZZA++-K16A	ON DELAY TIMER	=WD&EFS/6.4	=WD&EFS/6.3	=WD&EFS/7.6				
D PUSH BUTTON RED 2NO SIEMENS/TEKNIC/LAPTRON/Eq	1.00									
		=ZZA++-S20	CLOSING	=WD&EFS/2.2						
E NOTE: 1. Drawings Approval subject to valid type test reports, to be checked during acceptance tests. 2. For EPC contractors only				CHIEF ENGINEER/PROJECTS APTRANSCO/VS/VIJAYAWADA						
F 1. Minimum 300mm plinth shall be maintained for CT/PT/CVT/Isolators/IV/LA/Breakers in the substation during foundation works to ensure safe live to ground clearance per IE rules. 2. Since the supply of terminal connectors is not in the scope of manufacturer as mentioned in the drawings. The EPC contractor shall be instructed to supply the same line with CT/PT/CVT/Isolator/IVT/LA/Breaker's requirement and compatibility.										
Date	09.05.2023	CLIENT: Transmission Corporation of Andhra Pradesh Limited		SIEMENS LTD.		Descp:245KV,50KA,4000A				
Prep.	MSR	CONTRACTOR: As applicable		Aurangabad		SO NO: Qty:				
Ckd.	SB	PROJECT: As applicable				Type:3AP1FI				
Issue	Remarks	Date	Name	ORIGINAL/REPLACEMENT FOR/REPLACED BY:		Dwg. Name:Equipment List				
						Sh. 5				
						10 Sh.				

1	2	3	4	5	6	7	8			
DESIGNATION / TECHNICAL DATA	QTY.	ITEM DESIGNATION	FUNCTIONS	TOTAL ITEM REPRESENTATION AND OTHER TECHNICAL DATA						
A PUSH BUTTON GREEN 4NO SIEMENS/TEKNIC/LAPTRON/Eq	1.00	=ZZA++-S21	OPENING							
				=WD&EFS/4.2	=WD&EFS/5.2					
B PUSH BUTTON YELLOW 2NO+2NC SIEMENS/TEKNIC/LAPTRON/Eq	1.00	=ZZA++-S22	CTD CHECK							
				=WD&EFS/4.7	=WD&EFS/5.7	=WD&EFS/4.7	=WD&EFS/5.7			
C MCB FOR MOTOR 4 P, 10A 400VAC SIEMENS/C&S/Eq	1.00	=ZZA++-F16	MCB FOR MOTOR SUPPLY							
				=WD&EFS/8.2	=WD&EFS/8.3	=WD&EFS/8.3	=WD&EFS/8.1			
D SWITCH (LOCAL/REMOTE CONTROL) 5 POLE 2 WAY NON-LOCKABLE 16A 440VAC/DC Switron/Eq	1.00	=ZZA++-S13	LOCAL REMOTE SELECTOR SWITCH							
				=WD&EFS/2.2	=WD&EFS/5.2	=WD&EFS/7.7				
E ON/OFF SWITCH 5A, 240VAC ANCHOR/GREAT WHITE/Eq	4.00	=ZZA++-F11	ON/OFF SWITCH	=WD&EFS/8.8						
				=ZZA++-F11LA	=WD&EFS/8.7					
					=ZZA++-F11LB	=WD&EFS/8.7				
						=ZZA++-F11LC	=WD&EFS/8.8			
							NOTE: 1. Drawings Approval subject to valid type test reports, to be checked during acceptance tests. 2.For EPC contractors only.			

CHIEF ENGINEER/PROJECTS  
APTRANSCO/VS/VIJAYAWADA

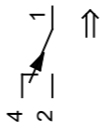
Date	09.05.2023	CLIENT:	Transmission Corporation of Andhra Pradesh Limited	SIEMENS LTD.	Descp:	245KV,50KA,4000A	SO NO:	Qty:	
Prep.	MSR	CONTRACTOR:	As applicable	Aurangabad	Type:	3AP1FI			
Ckd.	SB	PROJECT:	As applicable		Dwg. Name:	Equipment List			
Issue	Remarks	Date	Name	ORIGINAL/REPLACEMENT FOR/REPLACED BY:					Sh. 6
									10 Sh.

1	2	3	4	5	6	7	8
DESIGNATION / TECHNICAL DATA	QTY.	ITEM DESIGNATION	FUNCTIONS	TOTAL ITEM REPRESENTATION AND OTHER TECHNICAL DATA			
CAPACITOR TRIPPING DEVICE CTD MULTITECH 25W	2.00			 CAPACITOR - 1X Rc : CHARGING RESISTOR - 1X Rd : DISCHARG RESISTOR - 1X DIODE - 1X			
		=ZZA++-CTD1	CB TRIP IF DC FAILURE	=WD&EFS/4.7			
		=ZZA++-CTD2	CB TRIP IF DC FAILURE	=WD&EFS/5.7			
LIMIT SWITCH FOR SPRING CHARGING 1NO+1NC TECHNIQ MAKE./Eq	6.00			 NOTE: 1. Drawings Approval subject to valid type test reports, to be checked during acceptance tests. 2.For EPC contractors only.			
		=ZZA++-S16ALA	MOTOR LIMIT SWITCH	=WD&EFS/3.2			
		=ZZA++-S16ALB	MOTOR LIMIT SWITCH	=WD&EFS/3.2			
		=ZZA++-S16ALC	MOTOR LIMIT SWITCH	=WD&EFS/3.3			
		=ZZA++-S16BLA	MOTOR LIMIT SWITCH	=WD&EFS/6.7			
		=ZZA++-S16BLB	MOTOR LIMIT SWITCH	=WD&EFS/6.8			
		=ZZA++-S16BLC	MOTOR LIMIT SWITCH	=WD&EFS/6.8			
ILLUMINATION LAMP LED 240VAC 9W HAVELLS/ PHILIPS/Eq	4.00						
		=ZZA++-E2	ILLUMINATION LAMP	=WD&EFS/8.8			
		=ZZA++-E2LA	ILLUMINATION LAMP	=WD&EFS/8.7			
		=ZZA++-E2LB	ILLUMINATION LAMP	=WD&EFS/8.8			
		=ZZA++-E2LC	ILLUMINATION LAMP	=WD&EFS/8.8			
1. Minimum 300mm plinth shall be maintained for CT/PT/CVT/Isolators/IV/LA/Breakers in the substation during foundation works to ensure safe live to ground clearance per IE rules. 2. Since the supply of terminal connectors is not in the scope of manufacturer as mentioned in the drawings. The EPC contractor shall be instructed to supply the same line with CT/PT/CVT/Isolator/IVT/LA/Breaker's requirement and compatibility.							
<b>CHIEF ENGINEER/PROJECTS</b> <b>APTRANSCO/VISVIJAYAWADA</b>							
Date		09.05.2023		CLIENT: Transmission Corporation of Andhra Pradesh Limited		SIEMENS LTD.	
Prep.		MSR		CONTRACTOR: As applicable		Descp:245KV,50KA,4000A	
Ckd.		SB		PROJECT: As applicable		Type:3AP1FI	
Issue		Remarks		Date		Name	
						SO NO: Qty:	
						Dwg. Name:Equipment List	
				ORIGINAL/REPLACEMENT FOR/REPLACED BY:		Drg No: (3)G71AHS-NA403-E1503	
						Sh. 7	
						10 Sh.	

THE REPRODUCTION, TRANSMISSION OR USE OF THIS DOCUMENT OR ITS CONTENTS IS NOT PERMITTED UNLESS THE REPRODUCER IS A UTILITY MODEL OR DESIGN, ARE RESERVED.

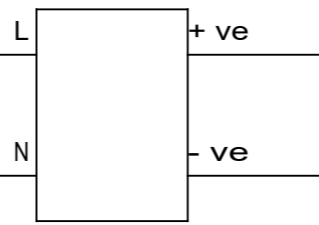
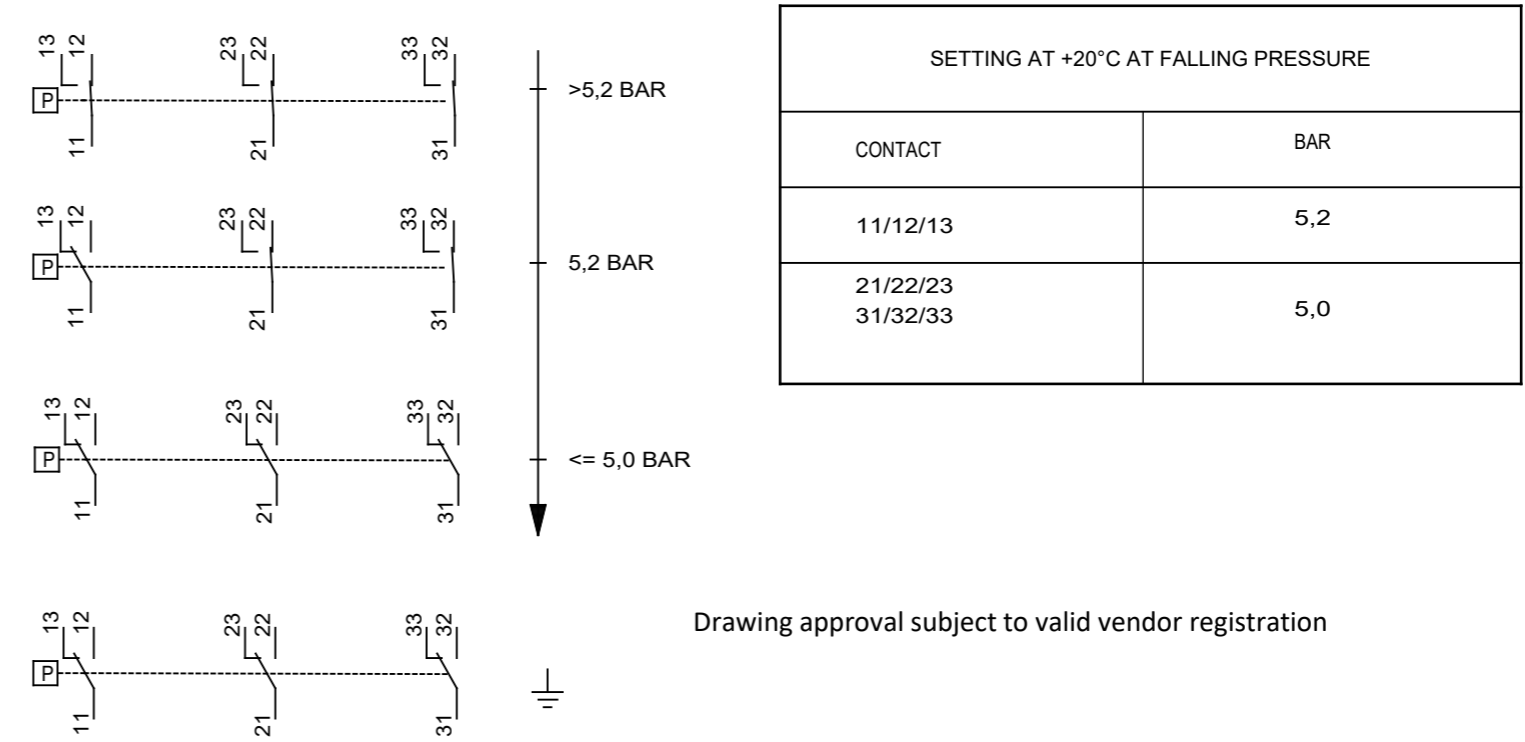
1	2	3	4	5	6	7	8								
DESIGNATION / TECHNICAL DATA	QTY.	ITEM DESIGNATION	FUNCTIONS	TOTAL ITEM REPRESENTATION AND OTHER TECHNICAL DATA											
A VOLTAGE ADAPTOR PSB2/24/24/1 230VAC/24VDC CONNECTWELL/Eq	1.00			 <p>NOTE: 1. Drawings Approval subject to valid type test reports, to be checked during acceptance tests. 2. For EPC contractors only.</p>											
		=ZZA++-POWER SUPPLY	VOLTAGE ADAPTER	=WD&EFS/8.5											
B DENSITY MONITOR SF6; 6BAR, 3 POLE COMDE/TRAFAG/EMD/WIKA/Eq	3.00			 <table border="1" style="margin-left: auto; margin-right: auto;"> <thead> <tr> <th colspan="2">SETTING AT +20°C AT FALLING PRESSURE</th> </tr> <tr> <th>CONTACT</th> <th>BAR</th> </tr> </thead> <tbody> <tr> <td>11/12/13</td> <td>5,2</td> </tr> <tr> <td>21/22/23 31/32/33</td> <td>5,0</td> </tr> </tbody> </table> <p style="text-align: center;">Drawing approval subject to valid vendor registration</p>				SETTING AT +20°C AT FALLING PRESSURE		CONTACT	BAR	11/12/13	5,2	21/22/23 31/32/33	5,0
		SETTING AT +20°C AT FALLING PRESSURE													
		CONTACT	BAR												
		11/12/13	5,2												
21/22/23 31/32/33	5,0														
=ZZA++-B4LA	SF6 MONITORING FOR POLE A	=WD&EFS/6.6	=WD&EFS/4.8	=WD&EFS/5.8											
=ZZA++-B4LB	SF6 MONITORING FOR POLE B	=WD&EFS/6.6	=WD&EFS/4.8	=WD&EFS/5.8											
=ZZA++-B4LC	SF6 MONITORING FOR POLE C	=WD&EFS/6.7	=WD&EFS/4.8	=WD&EFS/5.8											
<p>1. Minimum 300mm plinth shall be maintained for CT/PT/CVT/Isolators/IV/LA/Breakers in the substation during foundation works to ensure safe live to ground clearance per IE rules. 2. Since the supply of terminal connectors is not in the scope of manufacturer as mentioned in the drawings. The EPC contractor shall be instructed to supply the same line with CT/PT/CVT/Isolator/IV/LA/Breaker's requirement and compatibility.</p>															

THE REPRODUCTION, TRANSMISSION OR USE OF THIS DOCUMENT OR ITS CONTENTS IS NOT PERMITTED UNLESS THE REPRODUCER IS NOT PERMITTED OFFENDERS WILL BE LIABLE FOR DAMAGES. ALL RIGHTS, INCLUDING RIGHTS CREATED BY WITHOUT EXPRESS WRITTEN AUTHORITY, PATENT GRANT OR REGISTRATION OF A UTILITY MODEL OR DESIGN, ARE RESERVED.

Date	09.05.2023	CLIENT: Transmission Corporation of Andhra Pradesh Limited	<b>SIEMENS LTD.</b> Aurangabad	Descp:245KV,50KA,4000A	SO NO:	Qty:		
Prep.	MSR	CONTRACTOR: As applicable		Type:3AP1FI				
Ckd.	SB	PROJECT: As applicable		Dwg. Name:Equipment List				
Issue	Remarks	Date	Name	ORIGINAL/REPLACEMENT FOR/REPLACED BY:		Drg No: (3)G71AHS-NA403-E1503	Sh. 8	
							10 Sh.	

**CHIEF ENGINEER/PROJECTS**  
**APTRANSCO/VS/VIJAYAWADA**

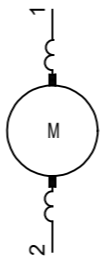
1	2	3	4	5	6	7	8
DESIGNATION / TECHNICAL DATA	QTY.	ITEM DESIGNATION	FUNCTIONS	TOTAL ITEM REPRESENTATION AND OTHER TECHNICAL DATA			
MOTOR UNIVERSAL 1PH 220VDC/AC 500W KPT/AGNI/Eq	3.00			 <p>NOTE: 1. Drawings Approval subject to valid type test reports, to be checked during acceptance tests. 2. For EPC contractors only.</p>			
		=ZZA++-M LA	SPRING CHARGING MOTOR				
		=ZZA++-M LB	SPRING CHARGING MOTOR	=WD&EFS/8.3			
		=ZZA++-M LC	SPRING CHARGING MOTOR	=WD&EFS/8.3	<p>1. Minimum 300mm plinth shall be maintained for CT/PT/CVT/Isolators/IV/LA/Breakers in the substation during foundation works to ensure safe live to ground clearance per IE rules. 2. Since the supply of terminal connectors is not in the scope of manufacturer as mentioned in the drawings. The EPC contractor shall be instructed to supply the same line with CT/PT/CVT/Isolator/IVT/LA/Breaker's requirement and compatibility.</p>		
<p><b>CHIEF ENGINEER/PROJECTS</b> <b>APTRANSCO/VS/VIJAYAWADA</b></p>							

THE REPRODUCTION, TRANSMISSION OR USE OF THIS DOCUMENT OR ITS CONTENTS IS NOT PERMITTED UNLESS THE REPRODUCER IS NOT PERMITTED OFFENDERS WILL BE LIABLE FOR DAMAGES. ALL RIGHTS, INCLUDING RIGHTS CREATED BY WITHOUT EXPRESS WRITTEN AUTHORITY, PATENT GRANT OR REGISTRATION OF A UTILITY MODEL OR DESIGN, ARE RESERVED.

Date	09.05.2023	CLIENT: Transmission Corporation of Andhra Pradesh Limited	<b>SIEMENS LTD.</b> Aurangabad	Descp:245KV,50KA,4000A	SO NO:	Qty:	
Prep.	MSR	CONTRACTOR:As applicable		Type:3AP1FI			
Ckd.	SB	PROJECT: As Applicable		Dwg. Name:Equipment List			
Issue	Remarks	Date	Name	ORIGINAL/REPLACEMENT FOR/REPLACED BY:		Drg No: (3)G71AHS-NA403-E1503	Sh. 9
							10 Sh.

A	DESIGNATION / TECHNICAL DATA		NOTE: 1. Drawings Approval subject to valid type test reports, to be checked during acceptance tests. 2.For EPC contractors only.					
	ITEM DESIGNATION							
	FUNCTIONS		TOTAL ITEM REPRESENTATION AND OTHER TECHNICAL DATA					
	AUXILIARY SWITCH 20NO+19NC+4Wi IMAX/SHIRKE							
	QTY. 3.00							
B								
C	=ZZA+-S1LA AUXILIARY SWITCH CB POLE A		=WD&EFS/3.5 =WD&EFS/9.1 =WD&EFS/2.3 =WD&EFS/2.3 =WD&EFS/2.6 =WD&EFS/9.6 =WD&EFS/9.6 =WD&EFS/6.2 =WD&EFS/6.2 =WD&EFS/9.6 =WD&EFS/9.7 =WD&EFS/9.2 =WD&EFS/9.2 =WD&EFS/9.2 =WD&EFS/9.3 =WD&EFS/9.3 =WD&EFS/9.3 =WD&EFS/9.4 =WD&EFS/9.4 =WD&EFS/9.4 =WD&EFS/9.5 =WD&EFS/9.5 =WD&EFS/9.5 =WD&EFS/9.6 =WD&EFS/9.8 =WD&EFS/9.7 =WD&EFS/3.7 =WD&EFS/3.7 =WD&EFS/4.3 =WD&EFS/6.4 =WD&EFS/4.3 =WD&EFS/6.4 =WD&EFS/4.3 =WD&EFS/5.3 =WD&EFS/5.3 =WD&EFS/9.7 =WD&EFS/9.7					
	=ZZA+-S1LB AUXILIARY SWITCH CB POLE B		=WD&EFS/3.6 =WD&EFS/9.1 =WD&EFS/2.4 =WD&EFS/2.4 =WD&EFS/2.6 =WD&EFS/9.6 =WD&EFS/9.6 =WD&EFS/6.2 =WD&EFS/6.2 =WD&EFS/9.6 =WD&EFS/9.7 =WD&EFS/9.2 =WD&EFS/9.2 =WD&EFS/9.2 =WD&EFS/9.3 =WD&EFS/9.3 =WD&EFS/9.3 =WD&EFS/9.4 =WD&EFS/9.4 =WD&EFS/9.4 =WD&EFS/9.5 =WD&EFS/9.5 =WD&EFS/9.5 =WD&EFS/9.6 =WD&EFS/9.8 =WD&EFS/9.7 =WD&EFS/3.7 =WD&EFS/3.7 =WD&EFS/4.4 =WD&EFS/6.4 =WD&EFS/4.5 =WD&EFS/6.4 =WD&EFS/4.5 =WD&EFS/4.5 =WD&EFS/5.4 =WD&EFS/5.4 =WD&EFS/5.5 =WD&EFS/5.5 =WD&EFS/9.7 =WD&EFS/9.7					
D	=ZZA+-S1LC AUXILIARY SWITCH CB POLE C		=WD&EFS/3.6 =WD&EFS/9.1 =WD&EFS/2.5 =WD&EFS/2.5 =WD&EFS/2.7 =WD&EFS/9.6 =WD&EFS/9.6 =WD&EFS/6.3 =WD&EFS/6.3 =WD&EFS/9.6 =WD&EFS/9.7 =WD&EFS/9.2 =WD&EFS/9.2 =WD&EFS/9.2 =WD&EFS/9.3 =WD&EFS/9.3 =WD&EFS/9.3 =WD&EFS/9.4 =WD&EFS/9.4 =WD&EFS/9.4 =WD&EFS/9.5 =WD&EFS/9.5 =WD&EFS/9.5 =WD&EFS/9.6 =WD&EFS/9.8 =WD&EFS/9.7 =WD&EFS/3.7 =WD&EFS/3.7 =WD&EFS/4.5 =WD&EFS/6.4 =WD&EFS/4.6 =WD&EFS/6.4 =WD&EFS/4.6 =WD&EFS/5.5 =WD&EFS/5.6 =WD&EFS/5.6 =WD&EFS/9.7 =WD&EFS/9.7					
E			1. Minimum 300mm plinth shall be maintained for CT/PT/CVT/Isolators/IV/LA/Breakers in the substation during foundation works to ensure safe live to ground clearance per IE rules. 2. Since the supply of terminal connectors is not in the scope of manufacturer as mentioned in the drawings. The EPC contractor shall be instructed to supply the same line with CT/PT/CVT/Isolator/IVT/LA/Breaker's requirement and compatibility.					
			CHIEF ENGINEER/PROJECTS APTRANSCO/VS/VIJAYAWADA					
F								

THE REPRODUCTION, TRANSMISSION OR USE OF THIS DOCUMENT OR ITS CONTENTS IS NOT PERMITTED UNLESS THE REPRODUCER IS A UTILITY MODEL OR DESIGN. ALL RIGHTS, INCLUDING RIGHTS CREATED BY WITHOUT EXPRESS WRITTEN AUTHORITY, PATENT GRANT OR REGISTRATION OF A UTILITY MODEL OR DESIGN, ARE RESERVED.

Date	09.05.2023	CLIENT: Transmission Corporation of Andhra Pradesh Limited	SIEMENS LTD.	Descp:245KV,50KA,4000A	SO NO:	Qty:	
Prep.	MSR	CONTRACTOR: As applicable	Aurangabad	Type:3AP1FI			
Ckd.	SB	PROJECT: As applicable		Dwg. Name:Equipment List			
Issue	Remarks	Date	Name	ORIGINAL/REPLACEMENT FOR/REPLACED BY:		Drg No: (3)G71AHS-NA403-E1503	Sh. 10
							10 Sh.

NOTE: 1. Drawings Approval subject to valid type test reports, to be checked during acceptance tests.  
2. For EPC contractors only.

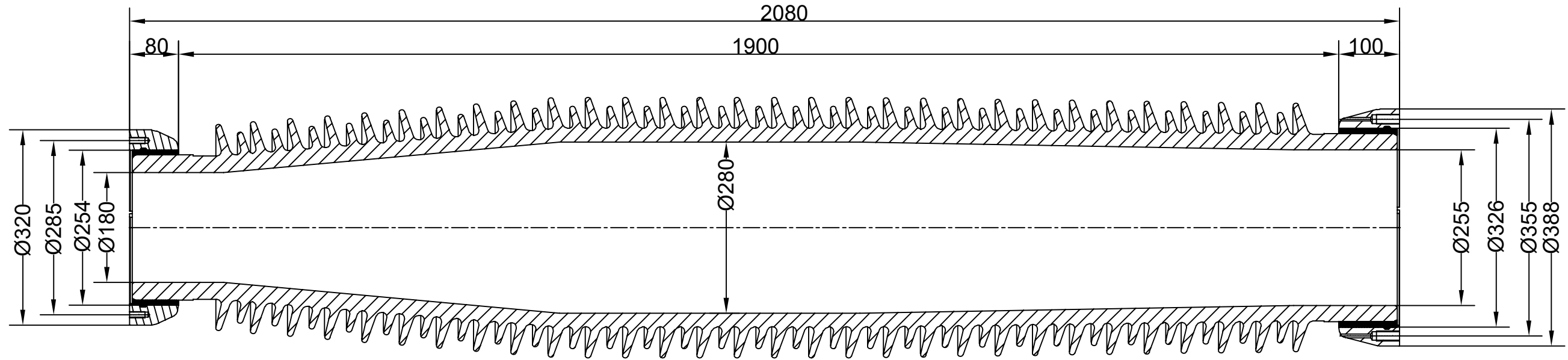

1. Minimum 300mm plinth shall be maintained for CT/PT/CVT/Isolators/IV/LA/Breakers in the substation during foundation works to ensure safe live to ground clearance per IE rules.
2. Since the supply of terminal connectors is not in the scope of manufacturer as mentioned in the drawings. The EPC contractor shall be instructed to supply the same line with CT/PT/CVT/Isolator/IVT/LA/Breaker's requirement and compatibility.

**MECHANICAL CHARACTERISTICS:**

1. Mechanical routine test: Pressure test 30 bar / 1 min
2. Mechanical routine test: Bending test  $F = 5250 \text{ N} / 10 \text{ sec} / 4 \times 90^\circ$
3. Design pressure 10 bar

**ELECTRICAL PARAMETERS FOR COMPLETE CB:**

1. 1 MIN. P.F. withstand voltage = 460 kV
2. Lightning Impulse withstand voltage = 1050 kV<sub>p</sub>

Min. creepage distance : 6125 mm

All unspecified dimensional tolerances are as per IEC 62155

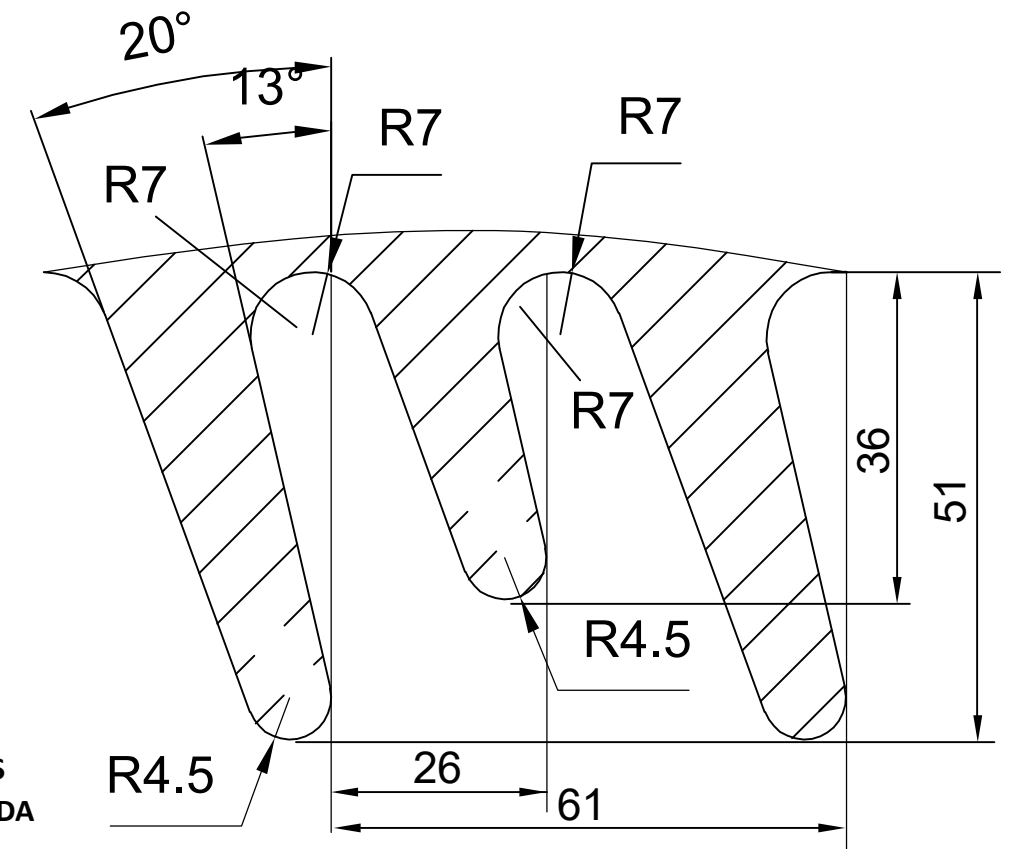

CHIEF ENGINEER/PROJECTS  
APTRANSCO/VS/VIJAYAWADA

Shed Profile as per IEC 60815

Date: 09.05.2023		CLIENT: Transmission Corporation of Andhra Pradesh Limited		Siemens Ltd.		Descr : 245kV,50kA,4000A SF6 CB.		SO No :		Qty:	
Prep: MSR		CONTRACTOR: As Applicable		AURANGABAD.		Type : 3AP1FI					
Ckd: SB		PROJECT: As Applicable				Details : Chamber Insulator(25mm/kV)		Drg. No:- (3)G71AHS-NA403-C1503-		Sh. 1	
Issue		Remarks		Date		Name		Norm.		Original / Replacement for /Replaced by :-	
G	G1	G2	G3	G4	G5	G6	G7				

H0/ESD-Coord/9E 03-90

F

The reproduction, transmission or use of this document or its contents is not permitted without express written authority of the originator. All rights, including rights created by patent grant or registration of a utility model or design, are reserved.

NOTE: 1. Drawings Approval subject to valid type test reports, to be checked during acceptance tests.  
 2. For EPC contractors only

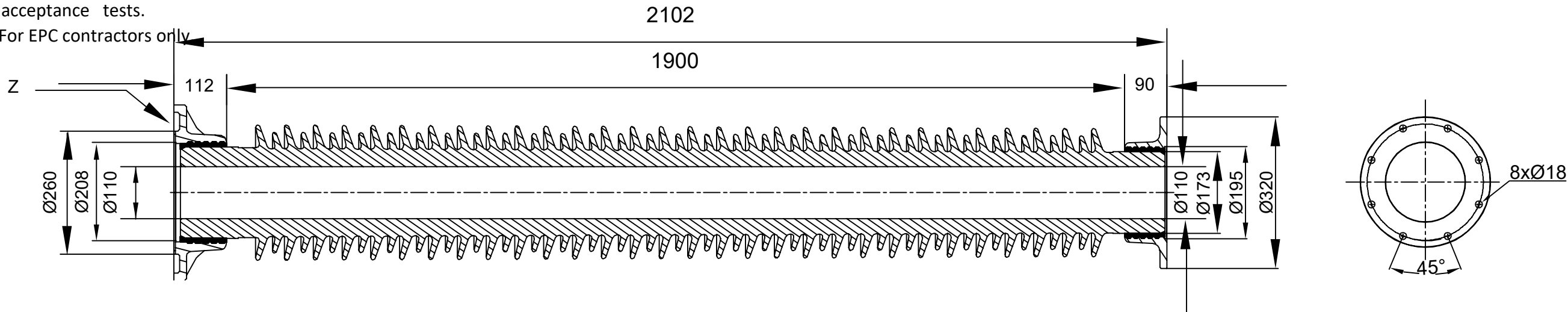

1. Minimum 300mm plinth shall be maintained for CT/PT/CVT/Isolators/IV/LA/Breakers in the substation during foundation works to ensure safe live to ground clearance per IE rules.
2. Since the supply of terminal connectors is not in the scope of manufacturer as mentioned in the drawings. The EPC contractor shall be instructed to supply the same line with CT/PT/CVT/Isolator/IVT/LA/Breaker's requirement and compatibility.

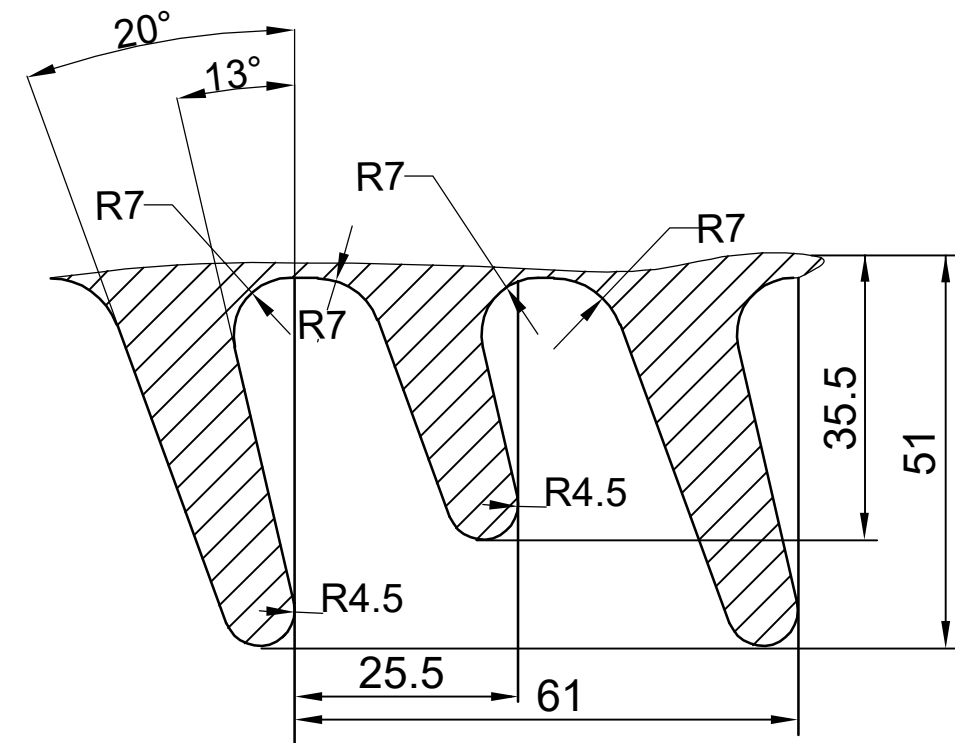
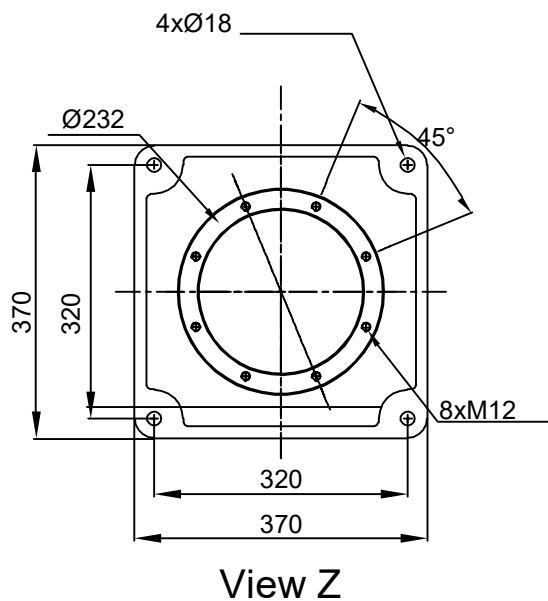

**MECHANICAL CHARACTERISTICS:**

1. Mechanical routine test: Pressure test 30 bar / 1 min
2. Mechanical routine test: Bending test F = 4667 N / 10 sec / 4 x 90°
3. Design pressure 10 bar

**ELECTRICAL PARAMETERS FOR COMPLETE CB:**

1. 1 MIN. P.F. withstand voltage = 460 kV
2. Lightning Impulse withstand voltage = 1050 kV<sub>p</sub>

Min. creepage distance : 6125 mm

All unspecified dimensional tolerances are as per IEC 62155

CHIEF ENGINEER/PROJECTS  
 APTRANSCO/VS/VIJAYAWADA

Drawing approval subject to valid vendor registration

Shed Profile as per IEC 60815

Date	09.05.2023	CLIENT: Transmission Corporation of Andhra Pradesh Limited	Siemens Ltd.	Descr : 245kV,50kA,4000A SF6 CB.	SO No :	Qty:
Prep	MSR	CONTRACTOR: As Applicable	AURANGABAD.	Type : 3AP1FI	Drg. No:- (3)G71AHS-NA403-C1503-	
Ckd.	SB	PROJECT: As Applicable		Details : Support Insulator(25mm/kV)	Sh. 2	
Issue		PO.NO.: As Applicable			4 Sh.	
Norm.		Original / Replacement for /Replaced by :-				