

NOTE : DRAWING APPROVAL SUBJECT TO VALID TYPE TEST REPORTS, TO BE CHECKED DURING ACCEPTANCE TESTS.

Drawing approval subject to valid vendor registration



**FOR EPC CONTRACTS ONLY**

**SCHEDULE-II**

**SCHEDULE OF GUARANTEED TECHNICAL PARTICULARS FOR 120kV 10kA TYPE-SM METAL OXIDE GAPLESS PORCELAIN LIGHTNING ARRESTER**

1. Name of Manufacturer : LAMCO INDUSTRIES PRIVATE LIMITED.  
H.O & WORKS: SANATHNAGAR-IE, HYD  
WORKS: AUTOMOTIVE PARK, TSIIC,  
MUPPIREDDYPALLY, T.S, INDIA.
2. Type/ : Station Class Metal Oxide Gapless Lightning Arresters, "MORESTER" type-SM, MODEL-'LMAS'  
  
Model (Drawing No.) : 2211206
3. Applicable standards : IEC 60099-4 of 2014
4. No.of Units & rating of each unit : 2 (60KV)
5. Rated Arrester voltage KWrms : 120
6. Rated Frequency Hz : 50
7. Max. continuous operating voltage KWrms : 106
8. Temporary PF overvoltage capacity (KVpeak) (with prior duty)
  - a) for 0.1 second KVP : 220
  - b) for 1 second KVP : 212
  - c) for 10 second KVP : 203
  - d) for 100 second KVP : 190
9. Nominal discharge current (8/20us) KA : 10
10. Long duration Energy discharge class : STATION MEDIUM
11. Min. energy discharge capability "KJ/KV of Ur" : 7  
(for 3 Sequential shots)
12. Seismic acceleration vertical & horizontal : 0.3g
13. Maximum switching current impulse : 280 KVP  
residual voltage at 1000A
14. Maximum residual voltage at nominal discharge current of 8/20 us wave
  - a) 5 KA KVpeak : 290
  - b) 10 KA KVpeak : 300
  - c) 20 KA KVpeak : 340
15. Min. prospective symmetrical current kA : 40

Chief Engineer  
Projects

**NOTE : DRAWING APPROVAL SUBJECT TO VALID TYPE TEST REPORTS, TO BE CHECKED DURING ACCEPTANCE TESTS.**

16. Max. steep front residual voltage at 10KA with one micro sec. rise time : 333 KV<sub>peak</sub>
17. Repetitive charge transfer rating Qrs : 1.6C
18. High current short duration (KAp) impulse withstand level with 4/10 us wave KAP : 100
19. Pressure relief class : A
20. a) Reference voltage Kv : Greater than the rated arrester voltage at 3mA reference current  
 b) Reference current mA : 3  
 c) Leakage current at COV mA : Less than 0.8
21. Minimum Total Creepage distance mm : 3625
22. Insulation withstand voltage of arrester housing  
 i) Lightning Impulse withstand voltage with 1.2/50us wave KV<sub>peak</sub> : 650  
 ii) Switching impulse KV<sub>peak</sub> : Not Applicable  
 iii) One minute PF withstand Voltage of housing (Dry & wet) KV<sub>rms</sub> : 275
23. Weight of complete unit Kgs : 104±10%
24. Overall Height of complete unit from base to line side mm : 1820 ±72  
**Drawing approval subject to valid vendor registration**
25. Minimum recommended spacing between center to center of LA mm : 2000
26. Min.distance between grounded object mm : 1700
27. Clearance required from ground equipment at various heights of arrester units mm : 1700
28. Earthing arrangement provided for earthing side of arrester. : provided (Ref Drg No:6220154).
29. Cantilever strength Kg : 500 (deflection 20mm)

1) Minimum 300mm plinth shall be maintained for CT/PT/CVT/Isolators in the substation during foundation works to ensure safe live to ground clearances as per IE rules.

2) Since the supply of terminal connectors is not in the scope of manufacturer as mentioned in the drawings, the EPC contractors shall be instructed to supply the same in line with CT/PT/CVT/Isolators requirement and compatibility.

Chief Engineer  
Projects

30. R.I.V @ 1.1 COV	: Less than 2500 $\mu$ V
31. Partial discharge @ 1.05 COV	: Less than 10pC
32. Details of metal oxide block :	
Reference voltage	: 4.5
Material	: Zno
Diameter	: 64 $\pm$ 2 mm
Height	: 34 $\pm$ 2 mm

for **LAMCO INDUSTRIES PRIVATE LIMITED.**



**(K. ARUN)**

**SENIOR MANAGER (D&D)**

**NOTE : DRAWING APPROVAL SUBJECT TO VALID TYPE TEST REPORTS, TO BE CHECKED DURING ACCEPTANCE TESTS.**

1) Minimum 300mm plinth shall be maintained for CT/PT/CVT/Isolators in the substation during foundation works to ensure safe live to ground clearances as per IE rules.

2) Since the supply of terminal connectors is not in the scope of manufacturer as mentioned in the drawings, the EPC contractors shall be instructed to supply the same in line with CT/PT/CVT/Isolators requirement and compatibility.

Chief Engineer  
Projects

Drawing approval subject to valid vendor registration

This drawing and design is the property of MEIL and must not be copied or lent without prior permission in writing

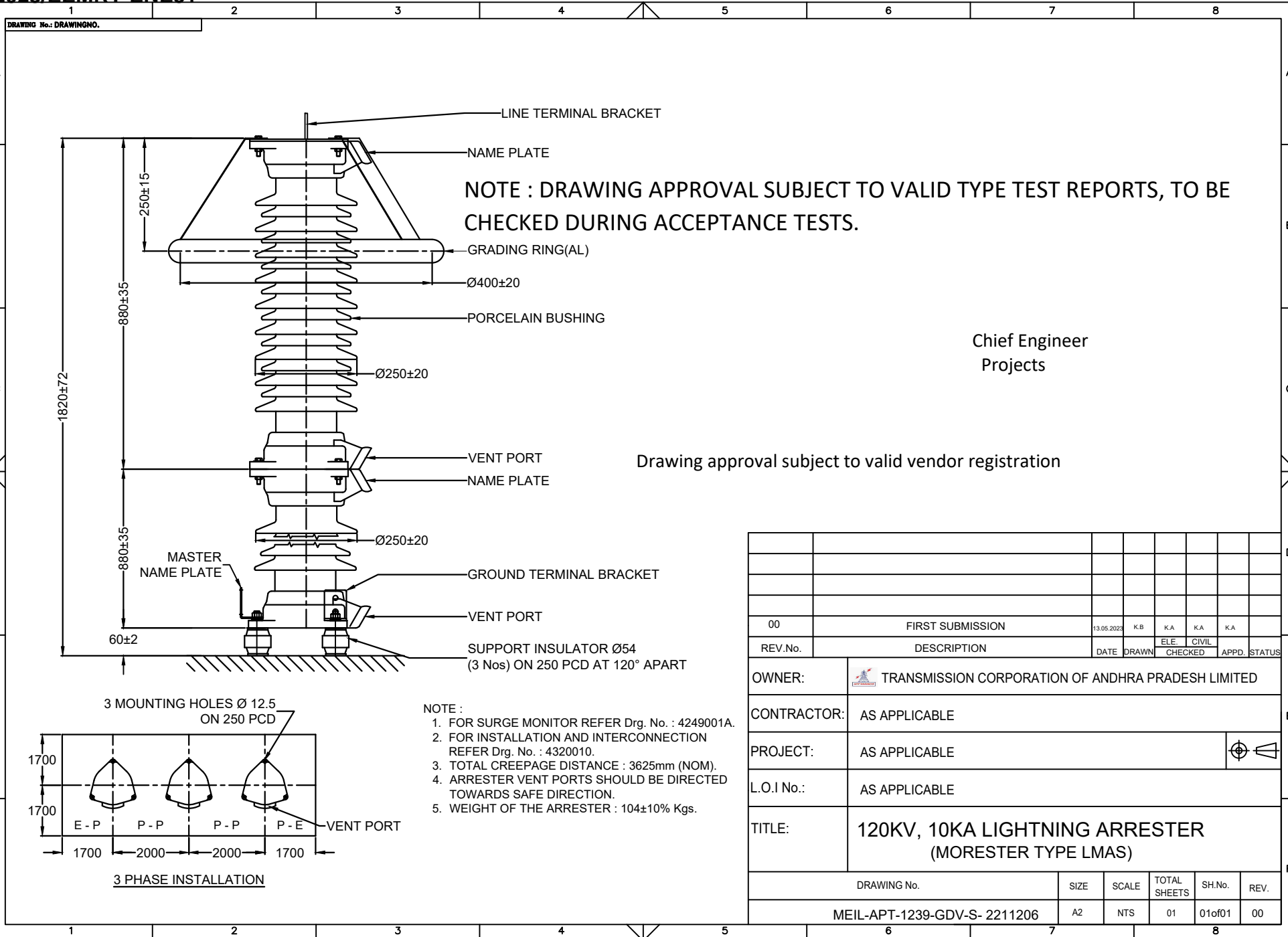

**NOTE : DRAWING APPROVAL SUBJECT TO VALID TYPE TEST REPORTS, TO BE CHECKED DURING ACCEPTANCE TESTS.**

Chief Engineer  
Projects

Drawing approval subject to valid vendor registration

00	FIRST SUBMISSION	13.05.2023	KB	KA	KA	KA	
REV.No.	DESCRIPTION	DATE	DRAWN	ELE. CHECKED	CIVIL	APPD.	STATUS
OWNER:		TRANSMISSION CORPORATION OF ANDHRA PRADESH LIMITED					
CONTRACTOR:		AS APPLICABLE					
PROJECT:		AS APPLICABLE					
L.O.I No.:		AS APPLICABLE					
TITLE:		120KV, 10KA LIGHTNING ARRESTER (MORESTER TYPE LMAS)					
DRAWING No.			SIZE	SCALE	TOTAL SHEETS	SH.No.	REV.
MEIL-APT-1239-GDV-S- 2211206			A2	NTS	01	01of01	00

- NOTE :**
1. FOR SURGE MONITOR REFER Drg. No. : 4249001A.
  2. FOR INSTALLATION AND INTERCONNECTION REFER Drg. No. : 4320010.
  3. TOTAL CREEPAGE DISTANCE : 3625mm (NOM).
  4. ARRESTER VENT PORTS SHOULD BE DIRECTED TOWARDS SAFE DIRECTION.
  5. WEIGHT OF THE ARRESTER : 104±10% Kgs.

3 PHASE INSTALLATION

This drawing and design is the property of MEIL and must not be copied or lent without prior permission in writing

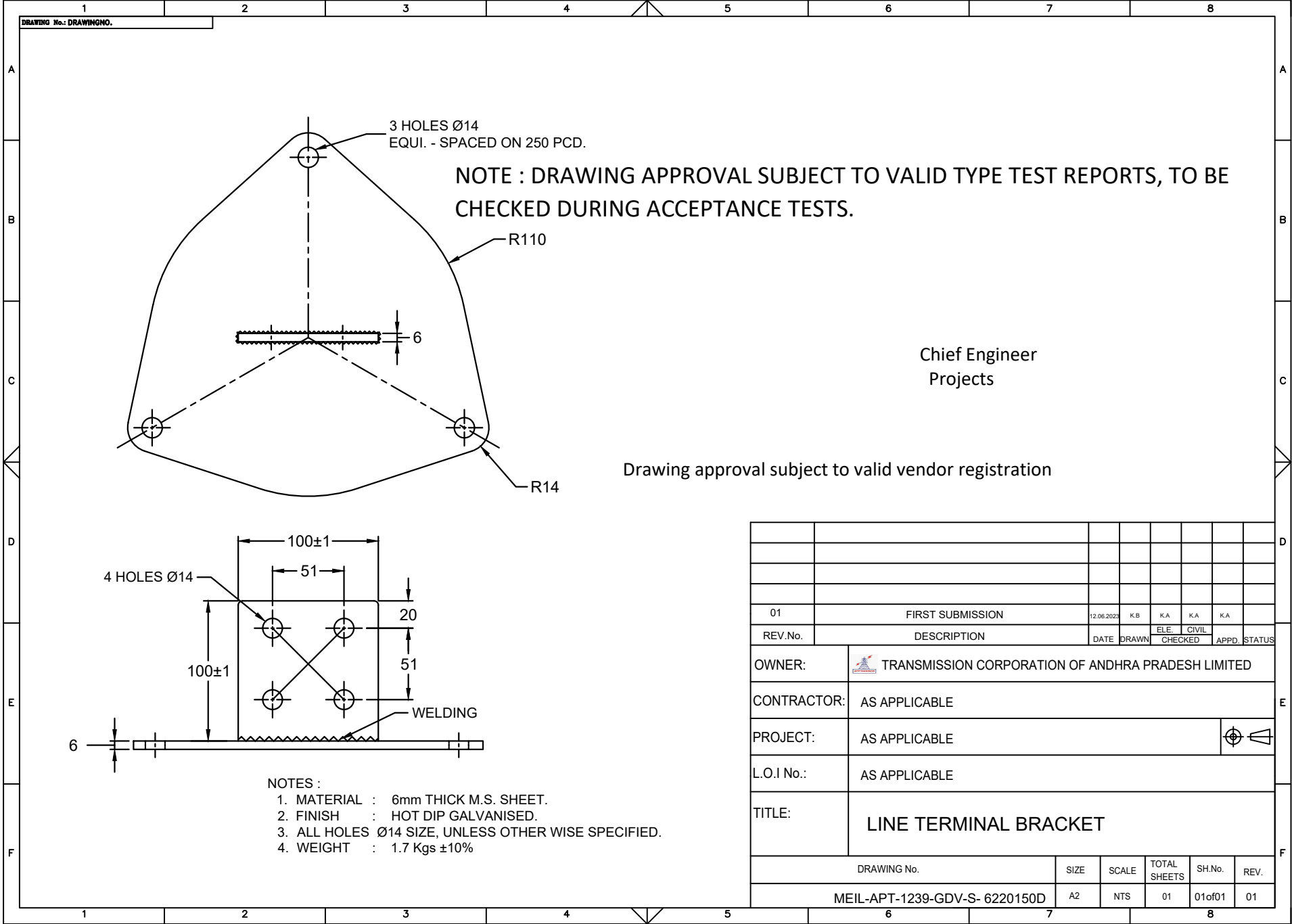

Chief Engineer  
Projects

Drawing approval subject to valid vendor registration

- NOTES :
1. MATERIAL : 6mm THICK M.S. SHEET.
  2. FINISH : HOT DIP GALVANISED.
  3. ALL HOLES Ø14 SIZE, UNLESS OTHER WISE SPECIFIED.
  4. WEIGHT : 1.7 Kgs ±10%

01	FIRST SUBMISSION	12.06.2023	K.B	K.A	K.A	K.A
REV.No.	DESCRIPTION	DATE	DRAWN	ELE. CHECKED	CIVIL	APPD. STATUS
OWNER:		TRANSMISSION CORPORATION OF ANDHRA PRADESH LIMITED				
CONTRACTOR:		AS APPLICABLE				
PROJECT:		AS APPLICABLE				
L.O.I No.:		AS APPLICABLE				
TITLE:		LINE TERMINAL BRACKET				
DRAWING No.		SIZE	SCALE	TOTAL SHEETS	SH.No.	REV.
MEIL-APT-1239-GDV-S- 6220150D		A2	NTS	01	01of01	01

This drawing and design is the property of MEIL and must not be copied or lent without prior permission in writing

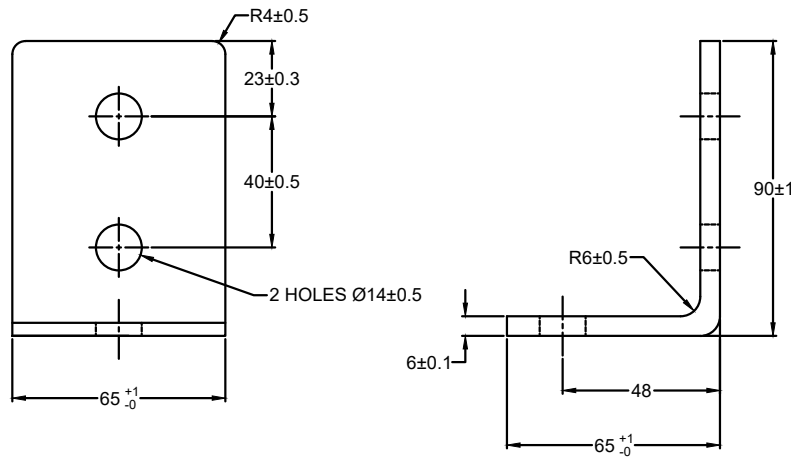
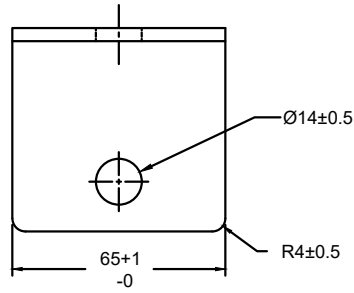

NOTE : DRAWING APPROVAL SUBJECT TO VALID TYPE TEST REPORTS, TO BE CHECKED DURING ACCEPTANCE TESTS.



- NOTE :
1. MATERIAL : M.S.PLATE.
  2. FINISH : HOT DIP GALVANISED.
  3. WEIGHT : 400 gms.±10%

Chief Engineer  
Projects

Drawing approval subject to valid vendor registration

00	FIRST SUBMISSION	13.05.2023	K.B	K.A	K.A	K.A
REV.No.	DESCRIPTION	DATE	DRAWN	ELE. CHECKED	CIVIL	APPD. STATUS
OWNER:  TRANSMISSION CORPORATION OF ANDHRA PRADESH LIMITED						
CONTRACTOR: AS APPLICABLE						
PROJECT: AS APPLICABLE						
L.O.I No.: AS APPLICABLE						
TITLE: GROUND TERMINAL BRACKET						
DRAWING No.		SIZE	SCALE	TOTAL SHEETS	SH.No.	REV.
MEIL-APT-1239-GDV-S- 6220154		A2	NTS	01	01of01	00

This drawing and design is the property of MEIL and must not be copied or lent without prior permission in writing

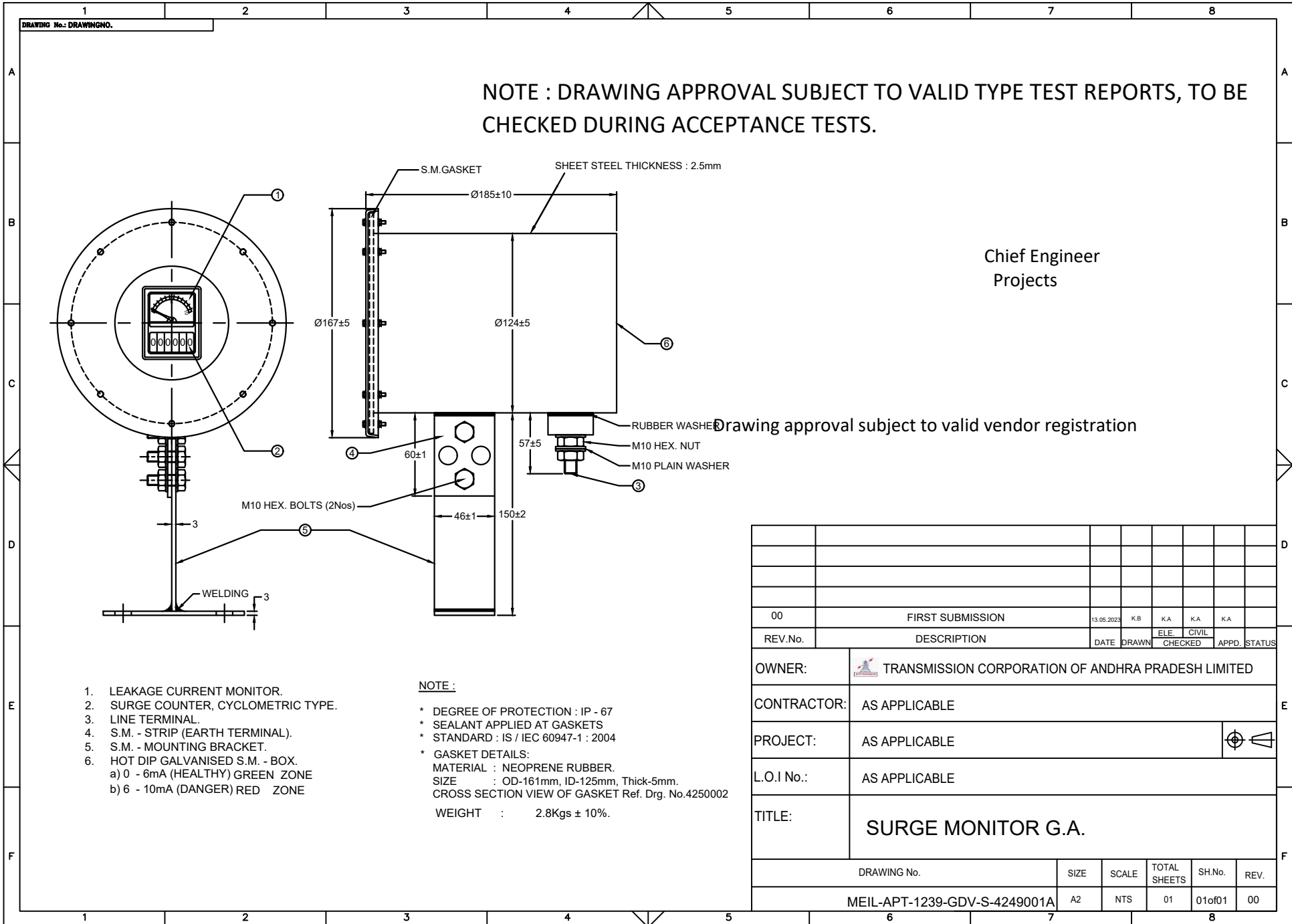

NOTE : DRAWING APPROVAL SUBJECT TO VALID TYPE TEST REPORTS, TO BE CHECKED DURING ACCEPTANCE TESTS.

Chief Engineer  
Projects

Drawing approval subject to valid vendor registration

- 1. LEAKAGE CURRENT MONITOR.
- 2. SURGE COUNTER, CYCLOMETRIC TYPE.
- 3. LINE TERMINAL.
- 4. S.M. - STRIP (EARTH TERMINAL).
- 5. S.M. - MOUNTING BRACKET.
- 6. HOT DIP GALVANISED S.M. - BOX.
  - a) 0 - 6mA (HEALTHY) GREEN ZONE
  - b) 6 - 10mA (DANGER) RED ZONE

**NOTE :**

- \* DEGREE OF PROTECTION : IP - 67
- \* SEALANT APPLIED AT GASKETS
- \* STANDARD : IS / IEC 60947-1 : 2004
- \* GASKET DETAILS:
- MATERIAL : NEOPRENE RUBBER.
- SIZE : OD-161mm, ID-125mm, Thick-5mm.
- CROSS SECTION VIEW OF GASKET Ref. Drg. No.4250002
- WEIGHT : 2.8Kgs ± 10%.

00	FIRST SUBMISSION	13.05.2023	K.B	K.A	K.A	K.A	
REV.No.	DESCRIPTION	DATE	DRAWN	CHECKED	APPD.	CIVIL	STATUS
OWNER:	TRANSMISSION CORPORATION OF ANDHRA PRADESH LIMITED						
CONTRACTOR:	AS APPLICABLE						
PROJECT:	AS APPLICABLE						
L.O.I No.:	AS APPLICABLE						
TITLE:	SURGE MONITOR G.A.						
DRAWING No.		SIZE	SCALE	TOTAL SHEETS	SH.No.	REV.	
MEIL-APT-1239-GDV-S-4249001A		A2	NTS	01	01of01	00	

This drawing and design is the property of MEIL and must not be copied or lent without prior permission in writing

- 1). Minimum 300 mm Plinth shall be maintained for Current transformers in the substation during foundation works to ensure safe live to ground clearances as per IE rules.
- 2). Since the supply of terminal connectors is not in the scope of CT Manufacturer as mentioned in the drawings, the EPC contractors shall be instructed to supply the same in line with the CT requirement and compatibility.

**NOTE : DRAWING APPROVAL SUBJECT TO VALID TYPE TEST REPORTS, TO BE CHECKED DURING ACCEPTANCE TESTS.**

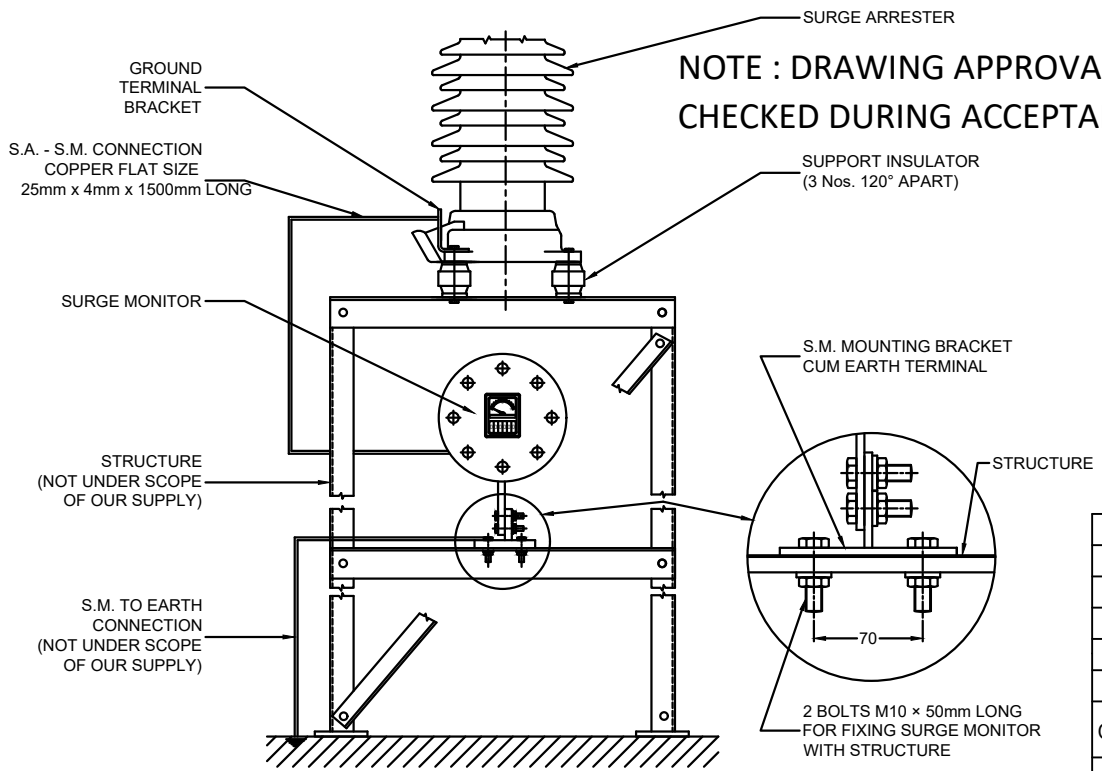

Chief Engineer  
Projects

Drawing approval subject to valid vendor registration

00	FIRST SUBMISSION	13.05.2023	KB	KA	KA	KA
REV.No.	DESCRIPTION	DATE	DRAWN	ELE. CHECKED	CIVIL	APPD. STATUS
OWNER:		TRANSMISSION CORPORATION OF ANDHRA PRADESH LIMITED				
CONTRACTOR:		AS APPLICABLE				
PROJECT:		AS APPLICABLE				
L.O.I No.:		AS APPLICABLE				
TITLE:		METHOD OF CONNECTING SURGE MONITOR WITH SURGE ARRESTER				
DRAWING No.		SIZE	SCALE	TOTAL SHEETS	SH.No.	REV.
MEIL-APT-1239-GDV-S- 4320010		A2	NTS	01	01of01	00

This drawing and design is the property of MEIL and must not be copied or lent without prior permission in writing

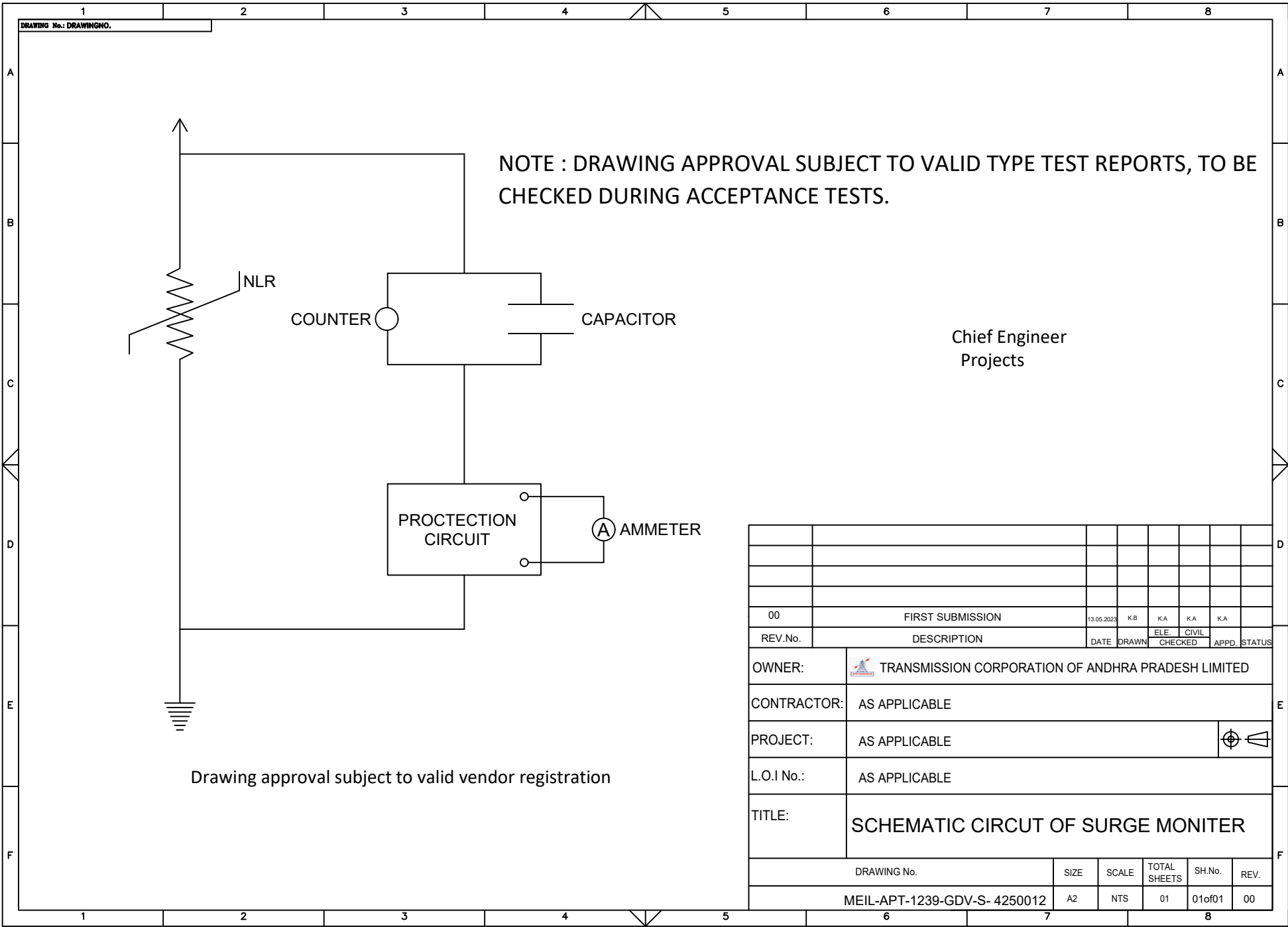

Chief Engineer  
Projects

REV.No.	DESCRIPTION	DATE	DRAWN	CHECKED	APPD.	STATUS
00	FIRST SUBMISSION	13.05.2023	K.B	K.A	K.A	K.A

OWNER:	TRANSMISSION CORPORATION OF ANDHRA PRADESH LIMITED				
CONTRACTOR:	AS APPLICABLE				
PROJECT:	AS APPLICABLE				
L.O.I No.:	AS APPLICABLE				
TITLE:	<b>SCHEMATIC CIRCUIT OF SURGE MONITOR</b>				
DRAWING No.	SIZE	SCALE	TOTAL SHEETS	SH.No.	REV.
MEIL-APT-1239-GDV-S- 4250012	A2	NTS	01	01of01	00

DRAWING No.: DRAWINGNO.

NOTE : DRAWING APPROVAL SUBJECT TO VALID TYPE TEST REPORTS, TO BE CHECKED DURING ACCEPTANCE TESTS.

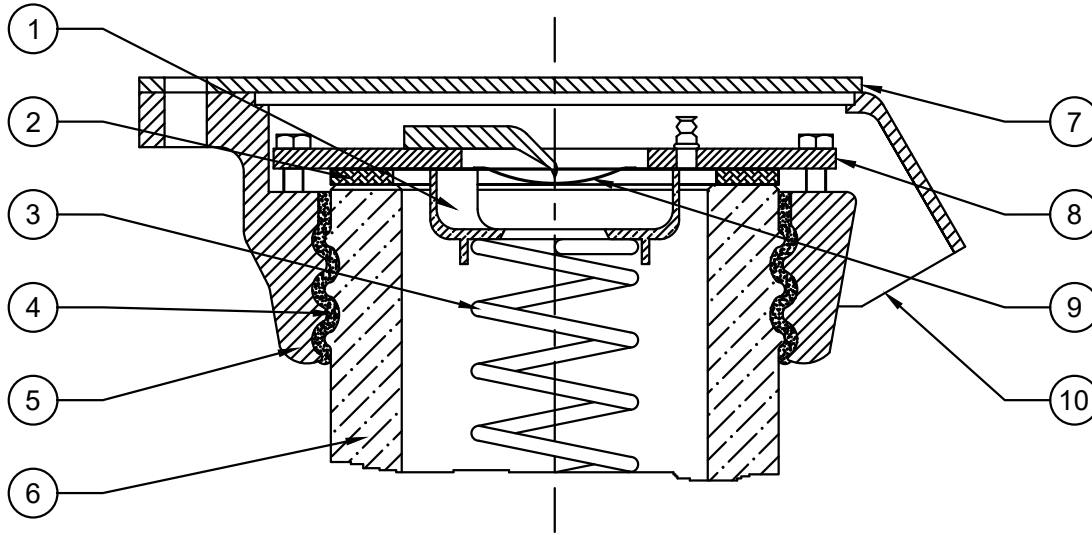

Chief Engineer  
Projects

Drawing approval subject to valid vendor registration

This drawing and design is the property of MEIL and must not be copied or lent without prior permission in writing

S.No.	ITEM	MATERIAL
1.	SP. SUPPORT.	ALUMINIUM
2.	RUBBER GASKET.	NEOPRENE ,5mm THICK
3.	SPRING.	SPRING STEEL
4.	SULPHUR CEMENT.	SULPHUR CEMENT
5.	CASTING.	ALUMINIUM (LM-6)
6.	BUSHING.	PORCELAIN
7.	END COVER PLATE.	ALUMINIUM
8.	COVER PLATE.	M.S (HOT DIP GALVANIZED)
9.	PRESSURE RELIEF DIAPHRAGM.	BRASS
10.	VENT PORT.	ALUMINIUM

00	FIRST SUBMISSION	13.05.2023	K.B	K.A	K.A	K.A	
REV.No.	DESCRIPTION	DATE	DRAWN	CHECKED	APPD.	STATUS	
OWNER:	TRANSMISSION CORPORATION OF ANDHRA PRADESH LIMITED						
CONTRACTOR:	AS APPLICABLE						
PROJECT:	AS APPLICABLE						
L.O.I No.:	AS APPLICABLE						
TITLE:	PRESSURE RELIEF AND SEALING ARRANGEMENT OF MORESTER						
DRAWING No.		SIZE	SCALE	TOTAL SHEETS	SH.No.	REV.	
MEIL-APT-1239-GDV-S- 4220041		A2	NTS	01	01of01	00	

DRAWING No.: DRAWINGNO.

NOTE : DRAWING APPROVAL SUBJECT TO VALID TYPE TEST REPORTS, TO BE CHECKED DURING ACCEPTANCE TESTS.

This drawing and design is the property of MEIL and must not be copied or lent without prior permission in writing

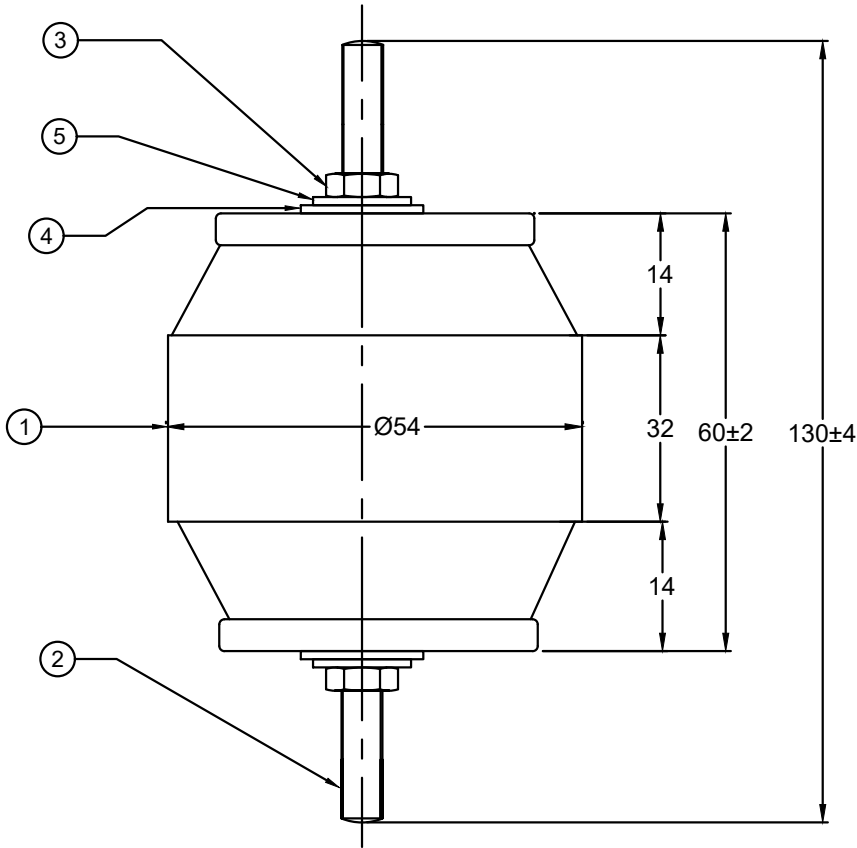

Chief Engineer  
Projects

Drawing approval subject to valid vendor registration

NOTE :  
 1. MATERIAL : POLYCRETE  
 2. HARDWARE : S.S  
 3. WEIGHT : 250 Grms±10%

5	SPRING WASHER M12	S.S.	2
4	PLAIN WASHER M12	S.S.	2
3	NUT M12	S.S.	2
2	STUD M12	S.S.	2
1	INSULATOR	POLYCRETE	1
ITEM	DESCRIPTION	MATERIAL	QTY.

01	FIRST SUBMISSION	02.08.2023	K.B	K.A	K.A	K.A
REV.No.	DESCRIPTION	DATE	DRAWN	CHECKED	APPD.	STATUS
OWNER:	TRANSMISSION CORPORATION OF ANDHRA PRADESH LIMITED					
CONTRACTOR:	meil AS APPLICABLE					
PROJECT:	AS APPLICABLE					
L.O.I No.:	AS APPLICABLE					
TITLE:	SUPPORT INSULATOR - Ø54 MODEL IB-14					
DRAWING No.		SIZE	SCALE	TOTAL SHEETS	SH.No.	REV.
MEIL-APT-1239-GDV-S-6221036		A2	NTS	01	01of01	01

This drawing and design is the property of MEIL and must not be copied or lent without prior permission in writing

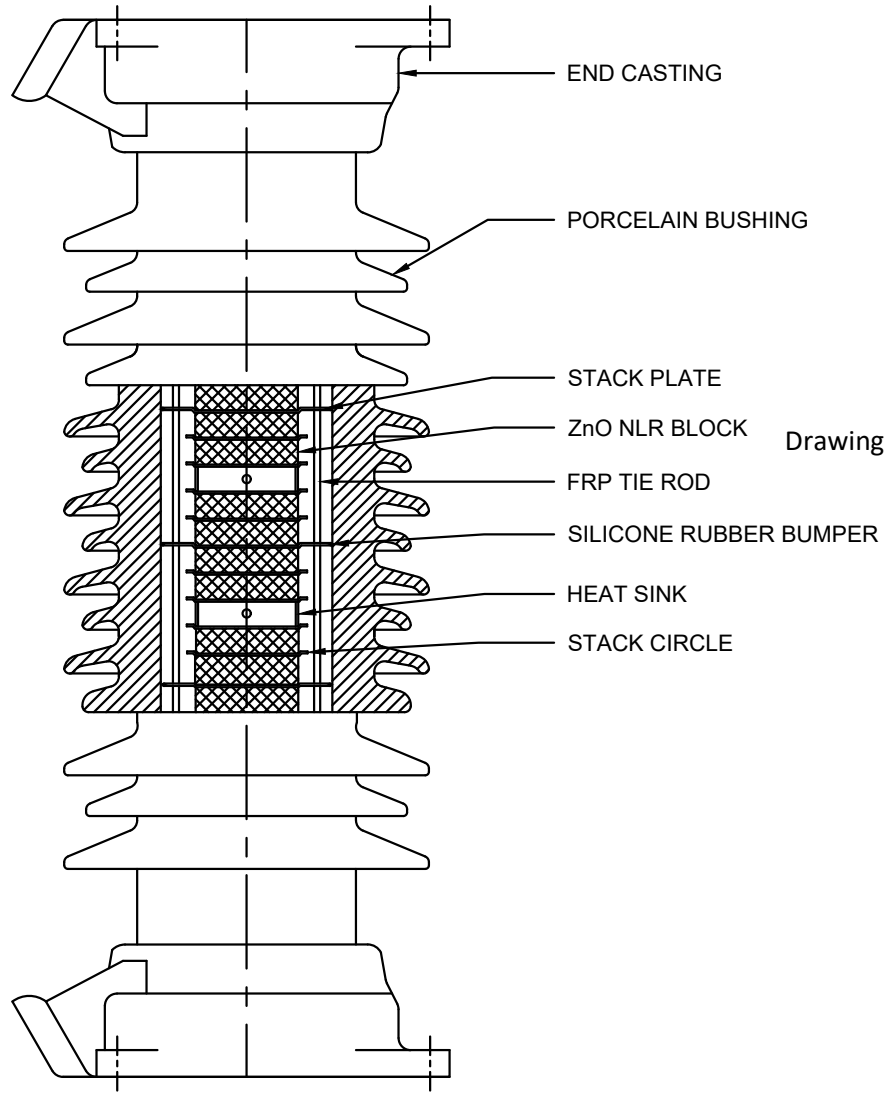

DRAWING No.: DRAWINGNO.

NOTE : DRAWING APPROVAL SUBJECT TO VALID TYPE TEST REPORTS, TO BE CHECKED DURING ACCEPTANCE TESTS.



Chief Engineer  
Projects

Drawing approval subject to valid vendor registration

00	FIRST SUBMISSION	13.05.2023	KB	KA	KA	KA	
REV.No.	DESCRIPTION	DATE	DRAWN	CHECKED	APPD.	STATUS	
OWNER:		 TRANSMISSION CORPORATION OF ANDHRA PRADESH LIMITED					
CONTRACTOR:		AS APPLICABLE					
PROJECT:		AS APPLICABLE 					
L.O.I No.:		AS APPLICABLE					
TITLE:		SECTIONAL VIEW OF MORESTER					
DRAWING No.		SIZE	SCALE	TOTAL SHEETS	SH.No.	REV.	
MEIL-APT-1239-GDV-S- 4220200		A2	NTS	01	01 of 01	00	

DRAWING No.: DRAWINGNO.

NOTE : DRAWING APPROVAL SUBJECT TO VALID TYPE TEST REPORTS, TO BE CHECKED DURING ACCEPTANCE TESTS.

Chief Engineer  
Projects

Drawing approval subject to valid vendor registration

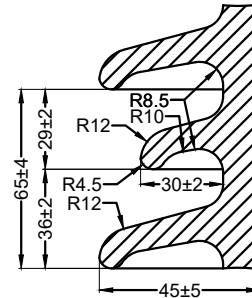
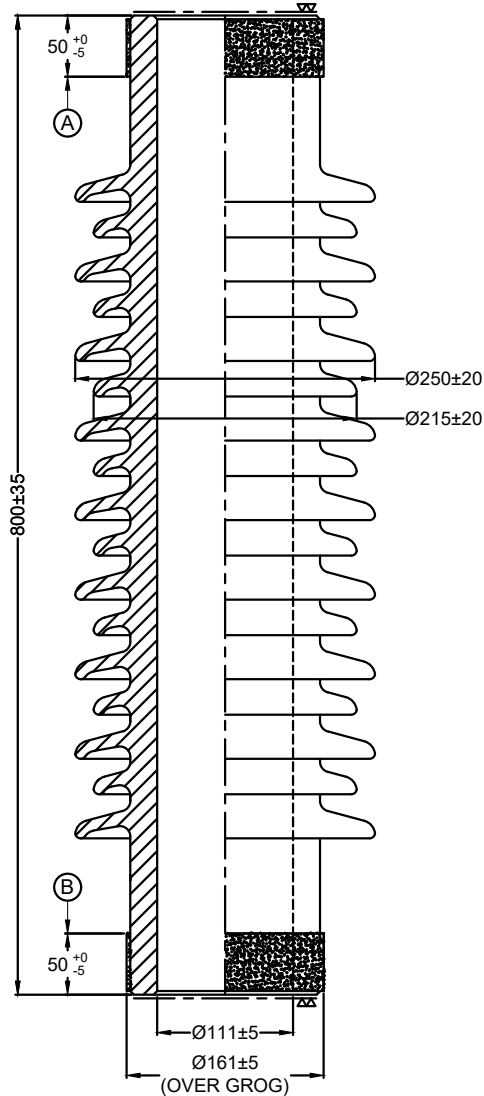

SHED DETAILS

- NOTE :
1. CREEPAGE DISTANCE FROM A TO B 1850 (NOM).
  2. SURFACES MARKED '∇' UNGLAZED, PARALLEL TO EACH OTHER AND PERPENDICULAR TO AXIS.
  3. GLAZE : DARK BROWN.
  4. BORE SHOULD BE STRAIGHT AND UNIFORM DIA.
  5. APPLICABLE STANDARD - IEC : 62155
  6. WEIGHT : 32±10% Kgs.

00	FIRST SUBMISSION	13.06.2023	K.B	KA	KA	KA	
REV.No.	DESCRIPTION	DATE	DRAWN	ELE. CHECKED	CIVIL	APPD.	STATUS
OWNER:		TRANSMISSION CORPORATION OF ANDHRA PRADESH LIMITED					
CONTRACTOR:		AS APPLICABLE					
PROJECT:		AS APPLICABLE					
L.O.I No.:		AS APPLICABLE					
TITLE:		PORCELAIN BUSHING - 6066					
DRAWING No.		SIZE	SCALE	TOTAL SHEETS	SH.No.	REV.	
MEIL-APT-1239-GDV-S- 6220004A		A2	NTS	01	01of01	00	

This drawing and design is the property of MEIL and must not be copied or lent without prior permission in writing

This drawing and design is the property of MEIL and must not be copied or lent without prior permission in writing

DRAWING No.: DRAWINGNO.

1) Minimum 300mm plinth shall be maintained for CT/PT/CVT/Isolators in the substation during foundation works to ensure safe live to ground clearances as per IE rules.

2) Since the supply of terminal connectors is not in the scope of manufacturer as mentioned in the drawings, the EPC contractors shall be instructed to supply the same in line with CT/PT/CVT/Isolators requirement and compatibility.

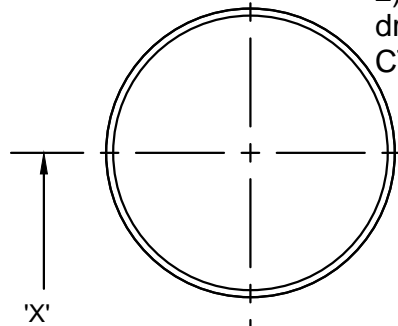

NOTE : DRAWING APPROVAL SUBJECT TO VALID TYPE TEST REPORTS, TO BE CHECKED DURING ACCEPTANCE TESTS.

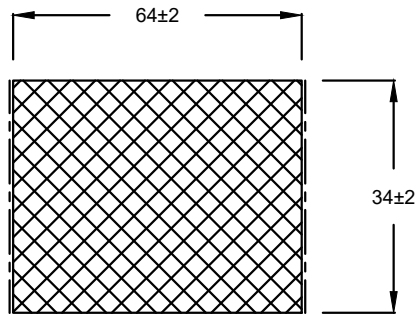

Drawing approval subject to valid vendor registration



SECTION AT 'XX'

MCOV : 3.82 KV rms  
Reference : 3 mA

Chief Engineer  
Projects

00	FIRST SUBMISSION	13.05.2023	K.B	K.A	K.A	K.A	
REV.No.	DESCRIPTION	DATE	DRAWN	ELE. CHECKED	CIVIL	APPD.	STATUS
OWNER:  TRANSMISSION CORPORATION OF ANDHRA PRADESH LIMITED							
CONTRACTOR: AS APPLICABLE							
PROJECT: AS APPLICABLE							
L.O.I No.: AS APPLICABLE							
TITLE: ZINC OXIDE BLOCK 4.5KV 10KA CLASS - 3							
DRAWING No.		SIZE	SCALE	TOTAL SHEETS	SH.No.	REV.	
MEIL-APT-1239-GDV-S- 6220080		A2	NTS	01	01of01	00	

This drawing and design is the property of MEIL and must not be copied or lent without prior permission in writing

DRAWING No.: DRAWINGNO.

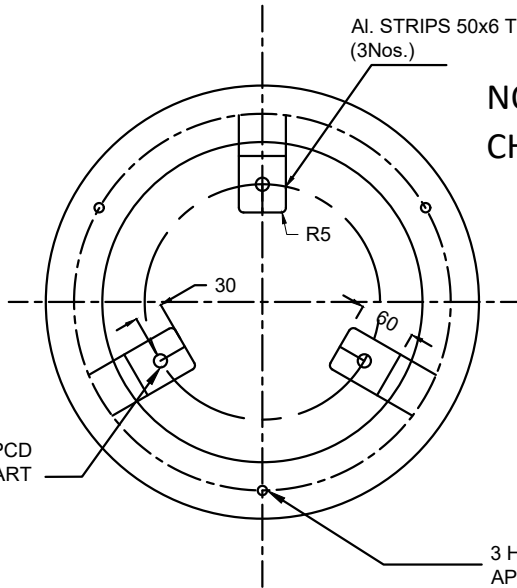

**NOTE : DRAWING APPROVAL SUBJECT TO VALID TYPE TEST REPORTS, TO BE CHECKED DURING ACCEPTANCE TESTS.**

Chief Engineer  
Projects

Drawing approval subject to valid vendor registration

TOP SURFACE SUBJECTED TO 180°

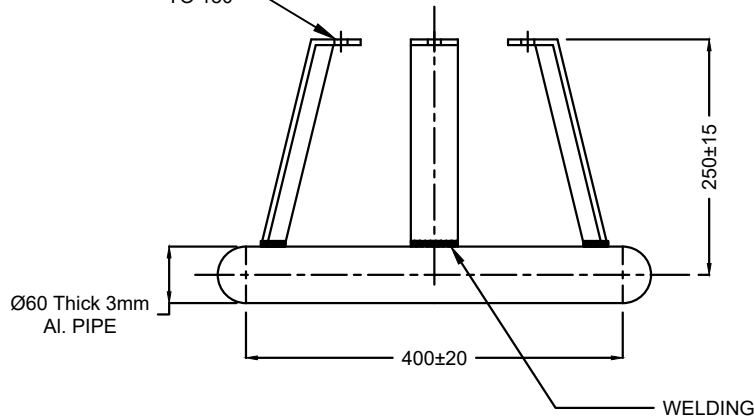

**NOTE :**  
 \* MATERIAL : ALUMINIUM  
 \* FINISH : BUFFING  
 \* SCRATCHES & SHARP CORNERS SHOULD BE NOT ALLOWED  
 \* WEIGHT : 2.8 Kg's ±10%

00	FIRST SUBMISSION	13.05.2023	K.B	K.A	K.A	K.A	
REV.No.	DESCRIPTION	DATE	DRAWN	CHECKED	APPD.	STATUS	
OWNER:		TRANSMISSION CORPORATION OF ANDHRA PRADESH LIMITED					
CONTRACTOR:		AS APPLICABLE					
PROJECT:		AS APPLICABLE					
L.O.I No.:		AS APPLICABLE					
TITLE:		GRADING RING - Ø400, Ht. 250mm					
DRAWING No.		SIZE	SCALE	TOTAL SHEETS	SH.No.	REV.	
MEIL-APT-1239-GDV-S- 6221038		A2	NTS	01	01 of 01	00	

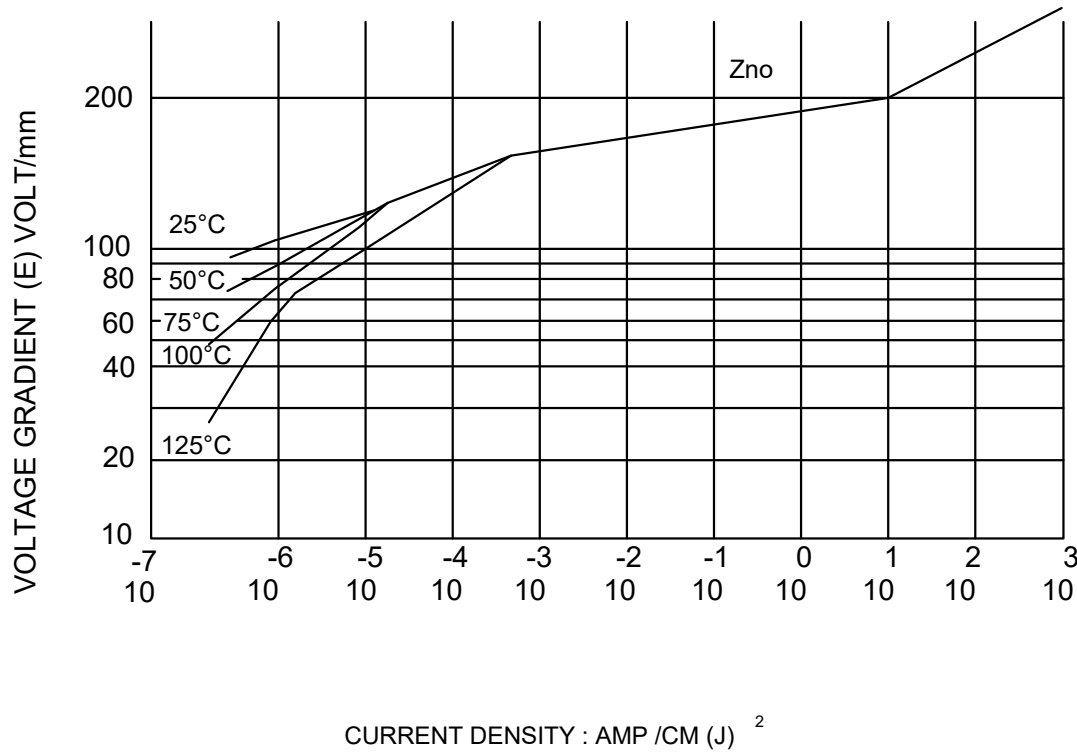

DRAWING No.: DRAWINGNO.

Drawing approval subject to valid vendor registration



**CHIEF ENGINEER /PROJECTS  
APTRANSCO/VIS/VIJAYAWADA**

This drawing and design is the property of MEIL and must not be copied or lent without prior permission in writing

00	FIRST SUBMISSION	13.05.2023	K.B	K.A	K.A	K.A	
REV.No.	DESCRIPTION	DATE	DRAWN	CHECKED	CIVIL	APPD.	STATUS
OWNER:		 TRANSMISSION CORPORATION OF ANDHRA PRADESH LIMITED					
CONTRACTOR:		AS APPLICABLE					
PROJECT:		AS APPLICABLE 					
L.O.I No.:		AS APPLICABLE					
TITLE:		<b>CHARACTERISTIC CURVES OF ZnO ELEMENTS</b>					
DRAWING No.		SIZE	SCALE	TOTAL SHEETS	SH.No.	REV.	
MEIL-APT-1239-GDV-S- 8221010		A2	NTS	01	01 of 01	00	

DRAWING No.- DRAWINGNO.

Drawing approval subject to valid vendor registration

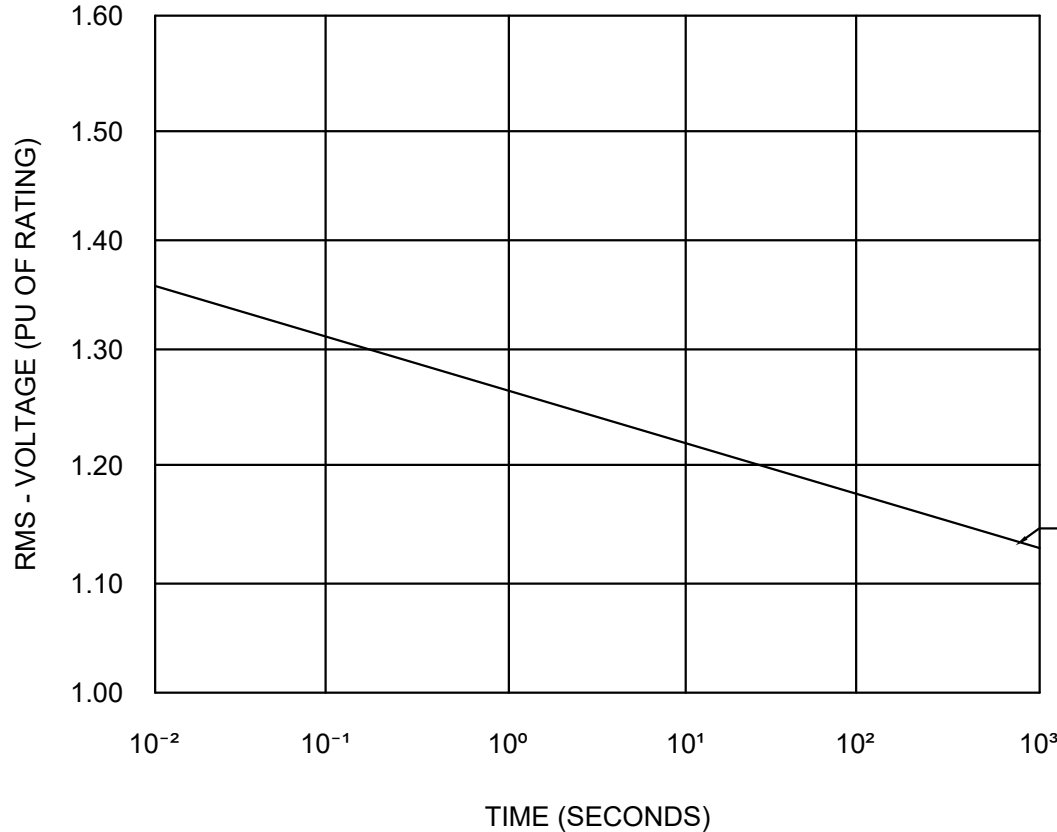

1) TOV CAPABILITY WITHOUT ENERGY ABSORPTION

**CHIEF ENGINEER /PROJECTS  
APTRANSCO/VISVIJAYAWADA**

REV.No.	DESCRIPTION	DATE	DRAWN	ELE. CHECKED	CIVIL	APPD.	STATUS
00	FIRST SUBMISSION	13.05.2023	K.B	K.A	K.A	K.A	
OWNER:		TRANSMISSION CORPORATION OF ANDHRA PRADESH LIMITED					
CONTRACTOR:		AS APPLICABLE					
PROJECT:		AS APPLICABLE					
L.O.I No.:		AS APPLICABLE					
TITLE:		POWER FREQUENCY VOLTAGE Vs TIME CHARACTERISTICS (10 KA)					
DRAWING No.		SIZE	SCALE	TOTAL SHEETS	SH.No.	REV.	
MEIL-APT-1239-GDV-S- 8221019		A2	NTS	01	01of01	00	

This drawing and design is the property of MEIL and must not be copied or lent without prior permission in writing

This drawing and design is the property of MEIL and must not be copied or lent without prior permission in writing

NOTE : DRAWING APPROVAL SUBJECT TO VALID TYPE TEST REPORTS, TO BE CHECKED DURING ACCEPTANCE TESTS.

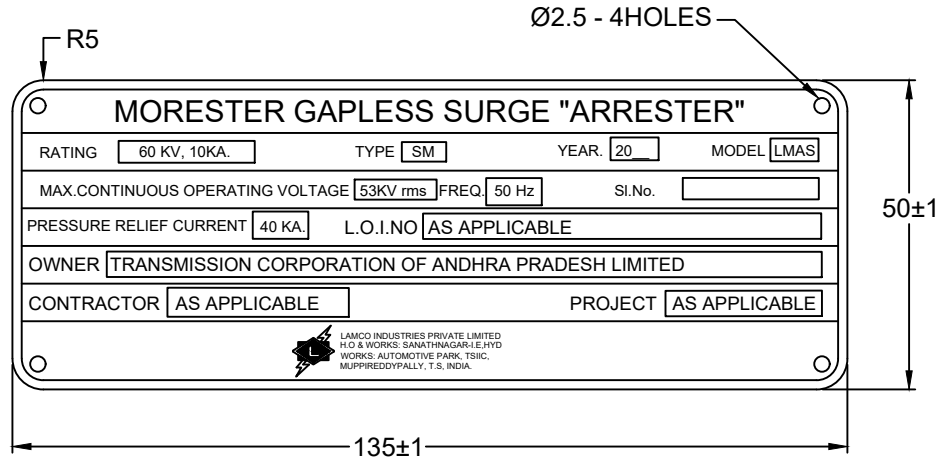

Chief Engineer  
Projects

Drawing approval subject to valid vendor registration

- NOTE: ± 0.05
1. MATERIAL : THICKNESS 0.51mm (25SWG) ALUMINIUM SHEET.
  2. PRINTING :
    - a. BORDER LINE AND LETTERS WITH ON BLACK BACKGROUND.
    - b. LETTER 'L' IN MONOGRAM IS BLACK ON WHITE BACK GROUND.
    - c. RECTANGULAR BLANKS WHITE, LETTERS BLACK.
    - d. LETTERS TO BE ETCHED.

REV.No.	DESCRIPTION	DATE	DRAWN	CHECKED	APPD.	STATUS
01	FIRST SUBMISSION	02.06.2023	K.B	KA	KA	KA
				ELE.	CIVIL	
OWNER:	TRANSMISSION CORPORATION OF ANDHRA PRADESH LIMITED					
CONTRACTOR:	AS APPLICABLE					
PROJECT:	AS APPLICABLE					
L.O.I No.:	AS APPLICABLE					
TITLE:	<b>GENERAL NAME PLATE MORESTER</b>					
DRAWING No.		SIZE	SCALE	TOTAL SHEETS	SH.No.	REV.
MEIL-APT-1239-GDV-S-8004401		A2	NTS	01	01 of 01	01

This drawing and design is the property of MEIL and must not be copied or lent without prior permission in writing

DRAWING No.: DRAWINGNO.

- 1). Minimum 300 mm Plinth shall be maintained for Current transformers in the substation during foundation works to ensure safe live to ground clearances as per IE rules.
- 2). Since the supply of terminal connectors is not in the scope of CT Manufacturer as mentioned in the drawings, the EPC contractors shall be instructed to supply the same in line with the CT requirement and compatibility.

<b>MORESTER GAPLESS SURGE "ARRESTER"</b>					
RATING	120KV, 10 KA	MODEL	LMAS		
MAX. CONTINUOUS OPERATING VOLTAGE	106 KV rms				
TYPE	SM				
PRESSURE RELIEF CURRENT	40 KA				
FREQ	50 Hz	BIL	650 KVp	YEAR	20
Sl. No.					
OWNER	TRANSMISSION CORPORATION OF ANDHRA PRADESH LIMITED				
CONTRACTOR	AS APPLICABLE				
L.O.I No	AS APPLICABLE				
PROJECT	AS APPLICABLE				
CREEPAGE DISTANCE	: 4495				
 LAMCO INDUSTRIES PRIVATE LIMITED H.O & WORKS: SANATHNAGAR-I.E, HYD WORKS: AUTOMOTIVE PARK, TSIC, MUPPIREDDYPALLY, T.S, INDIA.					

85±1.0



95±1.0

Ø2.5 HOLES (4Nos)

Chief Engineer  
Projects

Drawing approval subject to valid vendor registration

- NOTE: ±0.05
- 1) MATERIAL: THICKNESS 0.51mm (25 SWG) ALUMINIUM SHEET.
  - 2) PRINTING:-
    - a) BORDER LINE AND LETTERS WHITE ON BLACK BACKGROUND.
    - b) LETTER 'L' IN MONOGRAM IS BLACK ON WHITE BACKGROUND.
    - c) RECTANGULAR BLANKS WHITE, LETTERS BLACK.
    - d) LETTERS TO BE ETCHED.

01	FIRST SUBMISSION	02.06.2023	K.B	K.A	K.A	K.A
REV.No.	DESCRIPTION	DATE	DRAWN	CHECKED	APPD.	STATUS
OWNER:	 TRANSMISSION CORPORATION OF ANDHRA PRADESH LIMITED					
CONTRACTOR:	 AS APPLICABLE					
PROJECT:	AS APPLICABLE					
L.O.I No.:	AS APPLICABLE					
TITLE:	<b>MASTER NAME PLATE MORESTER</b>					
DRAWING No.		SIZE	SCALE	TOTAL SHEETS	SH.No.	REV.
MEIL-APT-1239-GDV-S-8004410		A2	NTS	01	01of01	01